



**High Performance
Precision Control
General Purpose Transducer Screwdriver**

Instruction Sheet

(1) General precautions

Thank you for purchasing this product. This instruction sheet provides information about the CHP ATX series transducer screwdrivers. Before using this product, read the instruction sheet to ensure the correct use of the product. Keep this sheet handy for quick reference whenever needed. Before finishing reading this sheet, follow these instructions:

- Make sure the installation location is free of corrosive and inflammable gas or vapor.
- Do not disassemble the transducer screwdriver or change the wiring when the power is on.

For more information about the ATX series servo screwdrivers, refer to the Transducer Screwdriver System user manual. To download the user manual, visit [CHP website at www.CHPTools.com](http://www.CHPTools.com). If you have any questions during operation, contact our local distributors or [CHP Customer Service](http://www.CHPTools.com). The instruction sheet may be revised without prior notice. Contact our distributors or download the latest version at [CHP website](http://www.CHPTools.com).

(2) Safety precautions

Pay special attention to the following safety precautions at all times during inspection, installation, wiring, operation, maintenance, and examination of the screwdriver.

The product is marked with following safety symbols:

	Danger. It might have potential danger to cause severe or fatal injures for personnel if the instructions are not followed.
	Warning. It might cause moderate injury to personnel, or lead to severe damage, malfunction of product if the instructions are not followed.
	Absolutely prohibited activities. It might cause serious damage or malfunction of product if the instructions are not followed.

Installation

- Do not expose the product to an environment containing corrosive and inflammable gas or vapor, or other foreign matter to reduce the risk of electric shock or fire.
- The controller for the transducer screwdrivers must be correctly grounded.
- Before connecting or removing the DC cable, ensure to turn off controller power.

Operation

- This product can be operated only by qualified personnel receiving the training for industrial assembly.
- This product is designed for intermittent use. Generally, operate the tool for 1 second and then stop it for 4 seconds. The allowable duty cycle is determined by the torque value and operating time. The built-in protection mechanism of this product ensures the allowable duty cycle is not exceeded.

- Do not touch any rotating parts when the tool is operating, since it might cause personnel injury.

Maintenance and inspection

- Do not use the cleaning fluid that contains solvents to clean the tool parts and tool cable.
- Only authorized personnel can repair and restart the system.

(3) Ambient conditions of installation



Ambient conditions for installing and operating the transducer screwdriver system: the environment should be free of devices that generate excessive heat; no water, vapor, dust, and oily dust; no corrosive and inflammable gas or liquids; no airborne dust or metal particles; and the environment should be solid without vibration and interference of electromagnetic noise.

Ambient conditions for operating the transducer screwdriver: the ambient temperature for operation is between 0°C (32°F) and 40°C (104°F). The environment should be free of devices that generate excessive heat; no water, vapor, dust, and oily dust; no corrosive and inflammable gas or liquids; no airborne dust or metal particles.

(4) How to use and install the transducer screwdriver

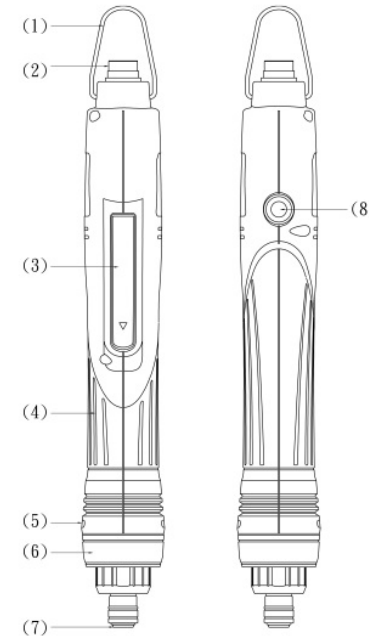

No.	Item	Description
(1)	Hanger	For securing the transducer screwdriver for easier operation.
(2)	Connector	Connects the transducer screwdriver to its controller.
(3)	Lever to start	Press this lever to start the transducer screwdriver.
(4)	Non-slip grip	When holding the transducer screwdriver during operation, this non-slip grip prevents the screwdriver from slipping off.
(5)	LED status indicator	Instantly shows the transducer screwdriver status:
(6)	LED illuminating light	The light is white and steady on when the power is supplied. You can set and adjust its functions and brightness via the controller.
(7)	Screwdriver shaft	For changing the bits. Use 1/4" (6.35 mm) hex bits.
(8)	Forward / reverse switch	Change the direction of rotation (forward or reverse) for the transducer screwdriver to tighten or loosen the screws.

Safety precautions for using the screwdriver:

- When removing or installing the screwdriver, hold the screwdriver body firmly instead of holding it only by its cable or rotating shaft.
- Do not hit the screwdriver shaft. Impact force will damage the shaft and the motor that is attached at the rear end of the shaft.
- The material of the screwdriver shaft is not rustproof. To ensure a longer product life, apply rustproof oil during operation. (add oil wd-40 or sewing machine oil before changing bit or after continuously operating over 5-7 days.)
- Turn off the power of the controller before replacing the screwdriver or DC cable. Otherwise, the screwdriver or DC cable may be damaged.
- Correctly connect and secure the DC cable. Avoid tangled and unsecured cables from causing wire damage and personnel injury.

Install the bit:

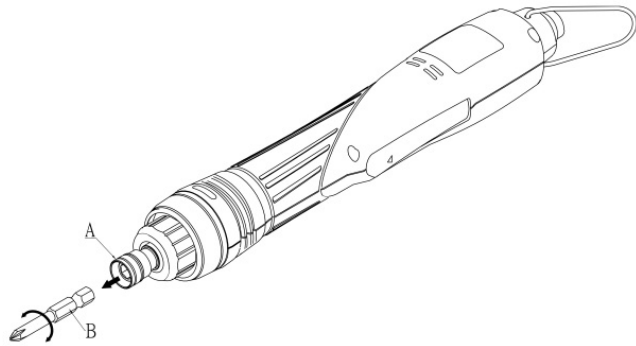

1. Pull out the chuck (A).
2. Insert the bit (B).
3. If not successful, rotate the bit (B) until it can be inserted.

Install the DC cable:

The DC cable connects the screwdriver to the controller. Note that the minimum bend radius (r) of the cable is 60 mm (2.36 inches).

Refer to the following figure. When DC cable connects to the screwdriver, align and mate the positioning notch on the plug and receptacle, and then rotate and tighten the nut in clockwise direction.

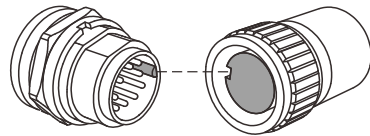
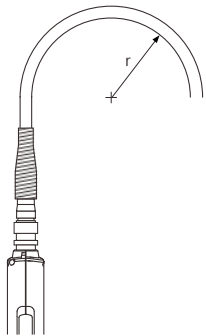

(5) Servo screwdriver specification

Model number	Torque range (kgf-cm)	Max. speed (rpm)	Bit size	Weight
ATX-12	2.4 - 12	2000	1/4" (6.35 mm) hex bit	480 g (1.06 lb)
ATX-30	6 - 30	1100		
ATX-50	10 - 50	700		

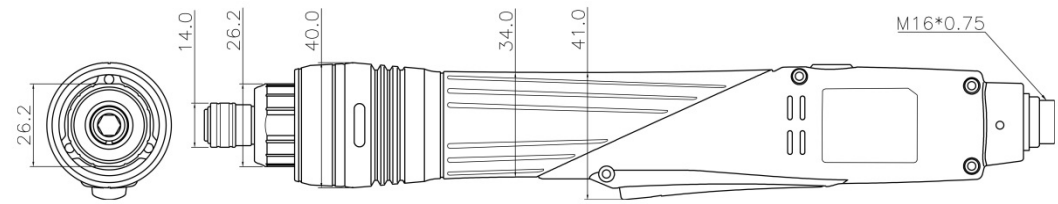

Note: the dimensions are in the unit of mm.

(6) Bit specifications

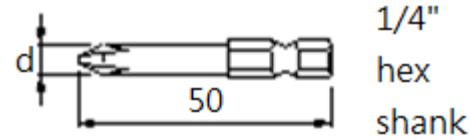

Tip No.	Tip diameter D 1/4"	Available Screwdriver Model
#1	ψ3.0	ATX-12
#2	ψ4.5	
#2	ψ4.5	ATX-30
#2	ψ6.0	
#2	ψ6.0	ATX-50
#2	ψ6.0	