



PATENTED

INSTRUCTION MANUAL

DPF-300

TABLE OF CONTENTS

This manual contains the following information:

INTRODUCTION	3
1. SAFETY RULES	4
1.1 MEANING OF THE SYMBOLS USED IN THIS MANUAL.....	4
1.2 GENERAL REQUIREMENTS	4
1.3 IDENTIFICATION PLATES ON THE MACHINE.....	4
1.4 MEANING OF THE WARNING PLATES AFFIXED TO THE MACHINE	5
2. MACHINE DESCRIPTION	7
3. TRANSPORT AND STORAGE	10
3.1 TRANSPORTING THE MACHINE	10
3.2 STORAGE CONDITIONS	10
4. MACHINE INSTALLATION	11
4.1 SPACE NEEDED FOR MACHINE OPERATION	11
4.2 CONDITIONS OF USE OF THE MACHINE	11
4.3 INSTALLATION PROCEDURE	12
5. INSTALLING/REPLACING THE GUIDE AND THE BIT	13
6. USING THE MACHINE	14
6.1 OPERATIONAL PHASES	15
6.2 PCB ORIENTATION	16
7. ENVIRONMENTAL IMPACT	17
8. WIRING DIAGRAM	18
9. MACHINE MAINTENANCE	19
9.1 ROUTINE MAINTENANCE	20
9.2 DUST FILTER CLEANING.....	21
9.3 MOTOR SPINDLE MAINTENANCE	22
10. TECHNICAL SPECIFICATIONS	23
10.1 GENERAL CHARACTERISTICS.....	23
10.2 CHARACTERISTICS OF THE PCBs TO BE SEPARATED	23
11. WARRANTY CONDITIONS	24
12. TECHNICAL SUPPORT	24
DPF-300 DECLARATION OF CONFORMITY	25

WARNING

The information contained in this document is subject to change at the discretion of the company without prior notice.

INTRODUCTION

CHP DPF-300 is a manual depaneling system designed to solve depaneling needs for small and medium production volumes, where a simple hand tool would entail excessive labor, but the production volume does not justify the cost of an automated depaneling system.

Among the features of the DPF-300 is the possibility to change the milling cutter and the INTERCHANGEABLE GUIDE (patented) quickly.

The INTERCHANGEABLE GUIDE assists the operator throughout the PCB positioning and dragging phase and speeds up the process leading up to isthmus (tab) cutting.

The special design of the INTERCHANGEABLE GUIDE avoids damage to the assembly in case of incorrect insertion. Thanks to its special shape, the assembly will be completely protected against accidents, in full compliance with the current safety standards.

The CHP DPF-300 is designed to mitigate any ***stress, break-off and tearing*** of PCB fibers. Such phenomena often occur when using blades or hand tools to separate the panels. As the complexity and miniaturisation of the printed circuit boards increases, these types of tools are less and less tolerated.

The CHP DPF-300 cuts the isthmus with the **precision of an automatic machine** at a much lower cost.

The electric extraction system of the DPF-300, placed directly on the INTERCHANGEABLE GUIDE, removes all the dust produced by the cutter, keeping the work area clean in accordance with the regulations.

1. SAFETY RULES

1.1 MEANING OF THE SYMBOLS USED IN THIS MANUAL



An exclamation mark in an equilateral triangle indicates that there are work or maintenance instructions to be observed or situations that are or may become particularly dangerous. The type of risk to which the operator is subject to and the level of skill required is also indicated.

1.2 GENERAL REQUIREMENTS



Before performing any maintenance or adjustment work, make sure that the power supply system is disconnected.

ATTENTION: American HAKKO Products, Inc. declines any liability for damages caused by the removal or modification, without authorization, of parts of the machine; it is also prohibited to carry out maintenance or adjustment during use of the machine.

The machine must be used exclusively for depaneling of FR4 or ALUMINIUM circuit board. Any other use is therefore prohibited and results in the immediate termination of the warranty on the product.

Comply with the instruction and warning labels on the machine.

The machine is built according to the safety criteria dictated by current regulations, indicated in the declaration of conformity attached to this manual.

1.3 IDENTIFICATION PLATES ON THE MACHINE

				
Mod. DPF-300				
S/N 0000		73 kg		
115 V	-	60 Hz	17 A	1 kW

DPF-300 MACHINE DATA PLATE

It is the identification plate of the machine, bearing its main specifications and its Serial Number. Located at the back of the machine.

Fig. 1

1.4 MEANING OF THE WARNING PLATES AFFIXED TO THE MACHINE



This symbol on the head baseplate indicates "DO NOT TOUCH" the cutter while it is running.



This symbol on the workbench indicates that the machine complies with standard CEI EN 61340-5-1 regarding the protection of electronic devices against electrostatic phenomena.



This symbol on the workbench indicates that eye and ear protection must be worn at all times while using the machine.



This symbol on the workbench indicates that protective gloves must be worn at all times while using the machine.



This symbol on the electric motor of the extraction system indicates that its surface may reach high temperatures. Do not touch this part during operation and wait for it to cool down after stopping the machine.



The lightning bolt symbol in an equilateral triangle alerts the user of the presence of "dangerous electricity" inside the product. This may constitute a risk of electrical discharges for the person who comes into contact with it.

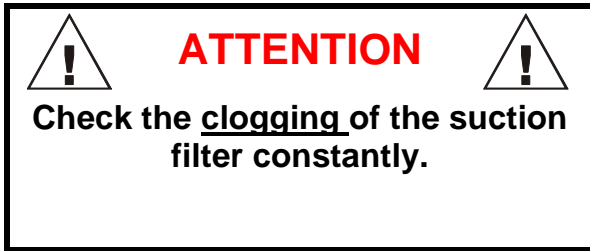

This plate, located on the front side of the machine, above the workbench, prompts the operator to check the clogging of the suction filter, constantly.

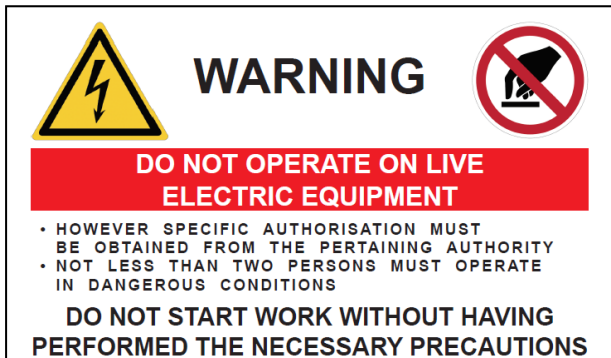

This plate, located on the front of the machine, precisely on the electrical panel, indicates that working on live electrical equipment is forbidden.

2. MACHINE DESCRIPTION

The machine (Fig.2) consists of steel frame with an ESD safe workbench on top, on which the milling head (cutter) is installed.

The frame is supported by two steel feet and two ESD safe swivel casters with brakes for practical positioning; the front side features an ESD connection port for the operator, thus rendering the machine compliant with standard IEC-61340-5-1.

A removable casing containing the electrical panel and the protective insulating casing of the motor spindle is fixed with screws to the bottom of the workbench. Control devices such as the disconnect switch, power indicator light, machine on/off switch and emergency button are located in front of the machine.

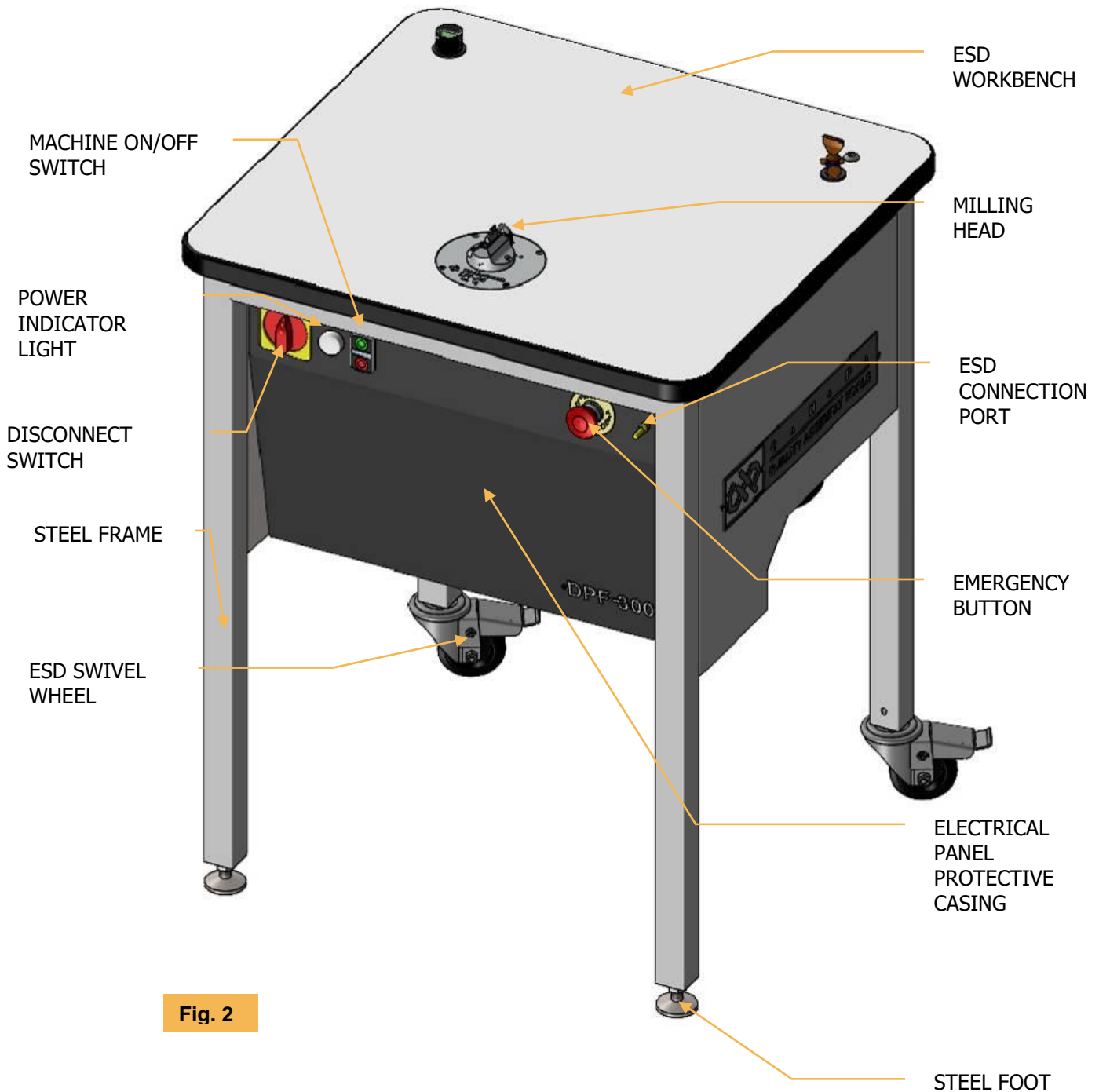

Fig. 2

The protective casing fixed with 4 screws on the back of the machine can be removed when carrying out maintenance work on the motor and the extraction system (Fig.3). Under the frame bedplate is a dust filter that features a special built-in filter cartridge, in accordance with EN 60335-269 and can easily be opened using the side clips.

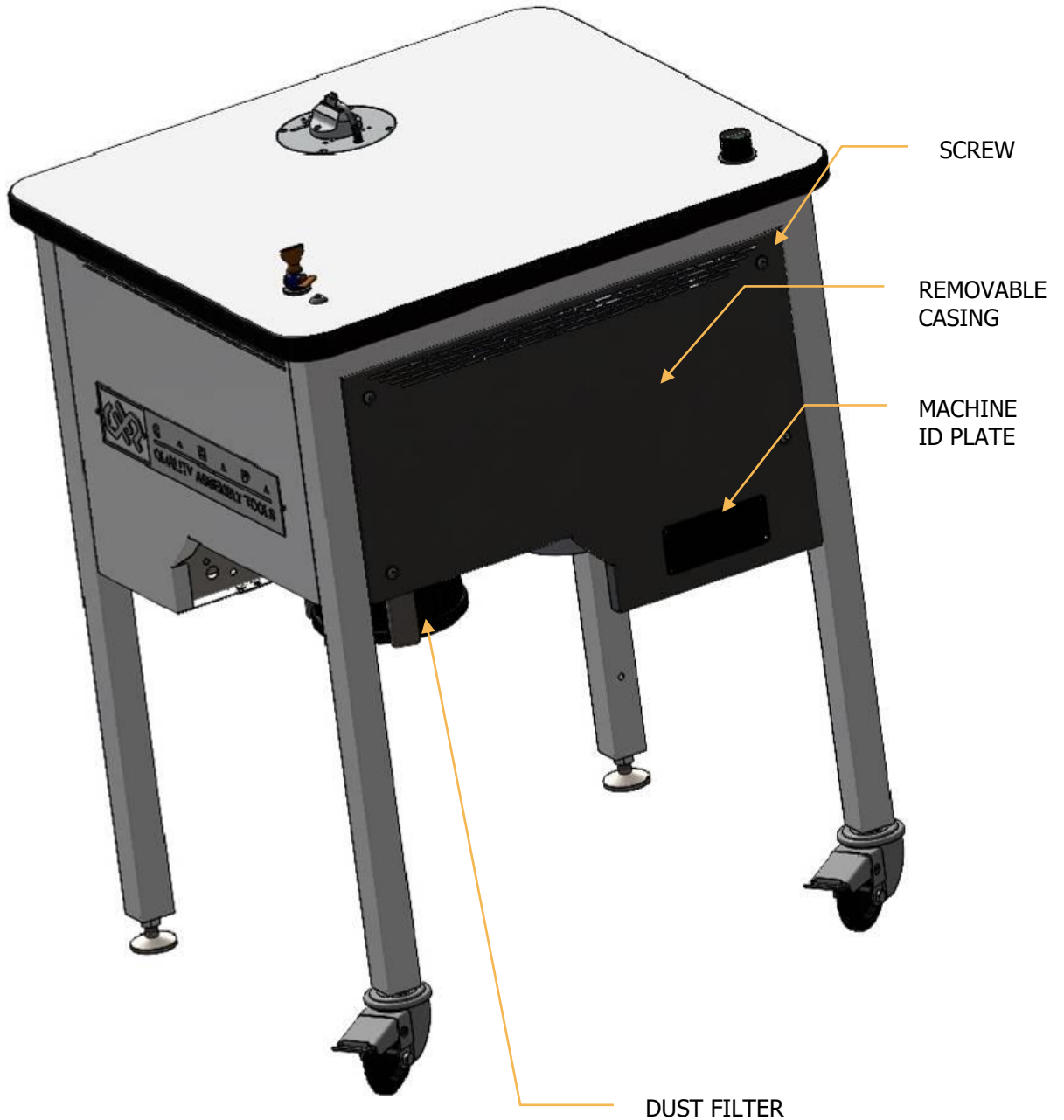

Fig. 3

The milling head consists of a bedplate and a mounting head on which a hardened ground steel interchangeable guide is installed (Fig.4).

The guide features a central slot along which the milling cutter moves. PCB dust is removed through the rear vacuum pipe that is connected to the electric extraction system and the corresponding dust filter; the first section of the pipe is made of stainless steel and then it continues with a black antistatic rubber tube.

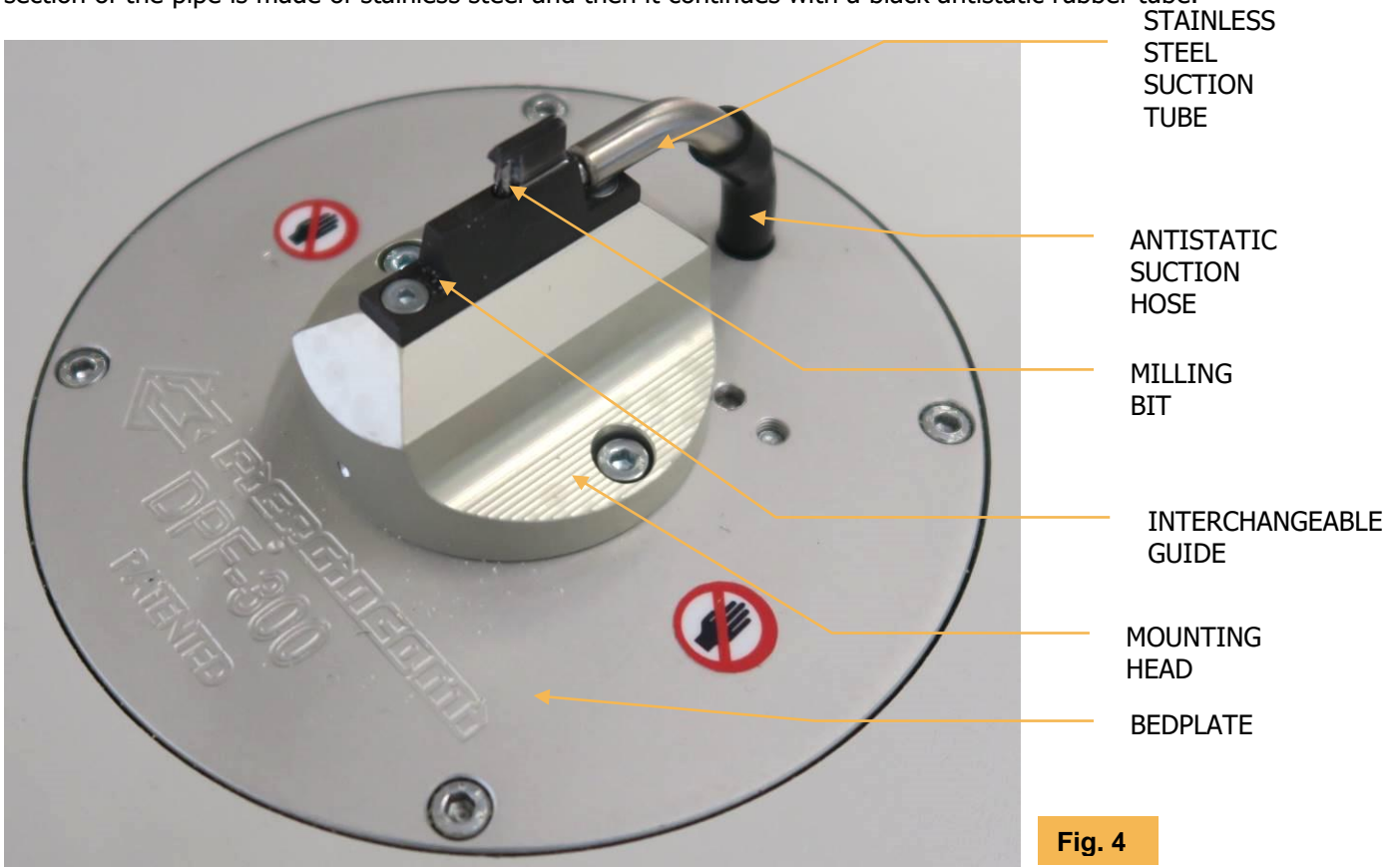

Fig. 4

Additional suction hose with built-in valve is located on the top right corner of the workbench (Fig. 5), used to clean the workbench from any dust residues.

An ORANGE (Fig.6) indicator light that turns on when the machine is running is located on the top left corner.

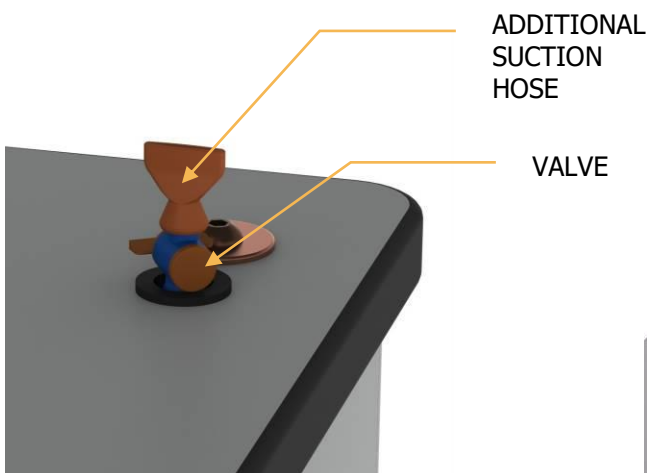

Fig. 5

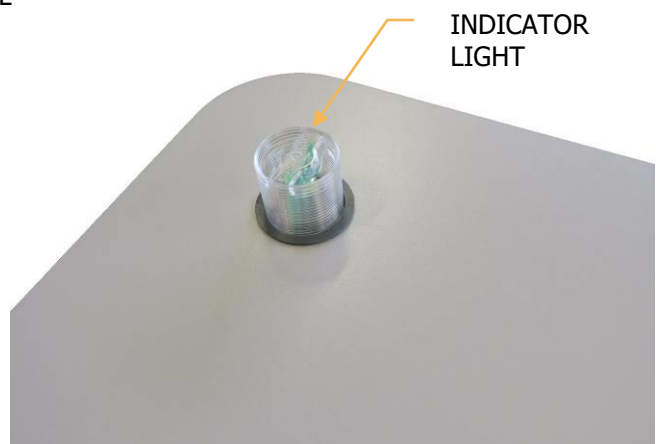

Fig. 6

3. TRANSPORT AND STORAGE



CAUTION!! All transport operations are to be carried out with the utmost care by specially trained personnel.

3.1 TRANSPORTING THE MACHINE

The machine must be transported on a pallet, covered with cardboard or placed in a wooden crate, respecting the total weight and dimensions indicated in Figure 7 below.

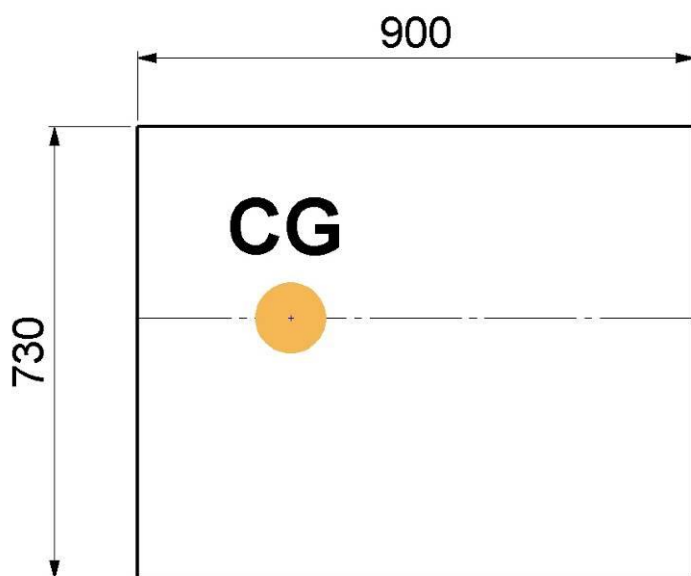

Pack. dim.
 Approx. 900 x 730 x 112 (h) mm.

Total machine weight (including the packaging)
 Wooden pallet and cardboard box: 90 kg.
 Wooden crate: 121 kg.

Fig. 7

3.2 STORAGE CONDITIONS

If DPF-300 is not installed immediately after delivery, store the machine in its original packaging, under the following conditions:

- Non-operating temperature: -10°C +50°C
- Humidity: less than 80%, non-condensing

4. MACHINE INSTALLATION



CAUTION!! The installation of DPF-300 requires a thorough knowledge of the machine and must, therefore, be entrusted only to specially trained personnel.

4.1 SPACE NEEDED FOR MACHINE OPERATION

The drawing below (Fig.8) indicates the minimum space (in millimeter) necessary for the correct operation and maintenance of DPF-300:

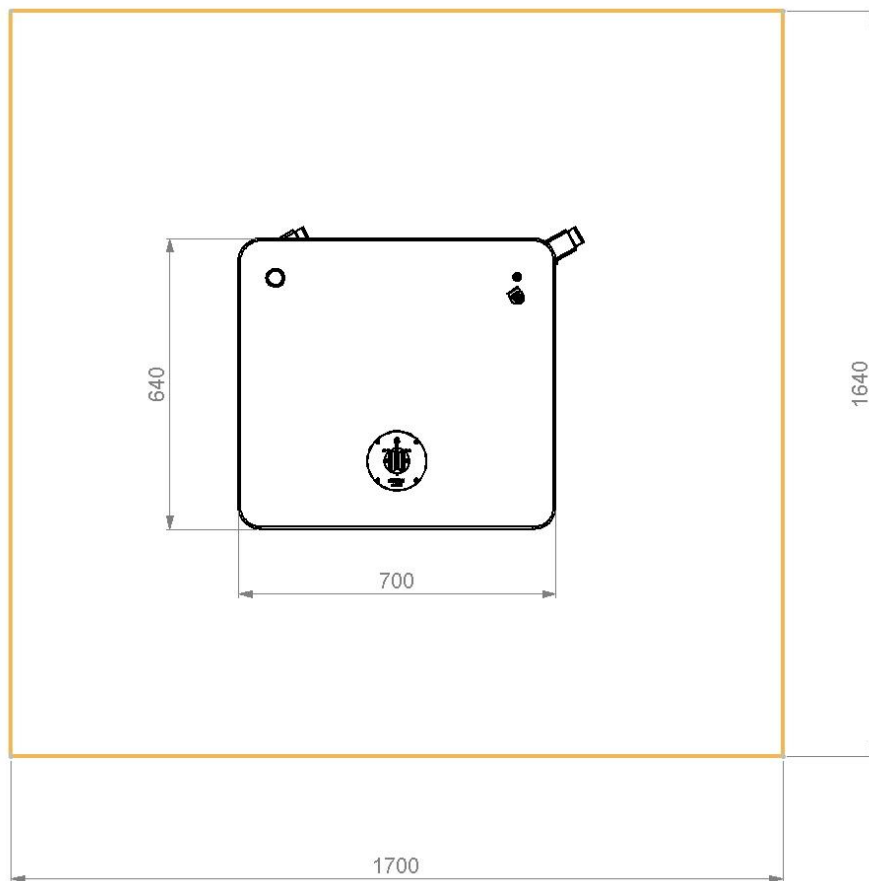

Fig. 8

4.2 CONDITIONS OF USE OF THE MACHINE

The main conditions for use of the machine are indicated below.

4.2.1 ENVIRONMENTAL CONDITIONS

- Operating temperature : 10 °C- 35 °C
- Non-operating temperature : 0°C-50°C
- Humidity : less than 70%, non-condensing
- Lighting conditions for the operator : high illuminance not required

4.3 INSTALLATION PROCEDURE

The machine comes with all its parts already assembled.

Before using the machine, perform the installation steps below:

- Adjust the height of the 2 feet making sure that they rest correctly on the ground and secure their position with the locking nuts.
- Lock the swivel wheels using the dedicated brake.
- Connect the machine to the main power (section 4.3.1)
- Install the milling bit and the interchangeable guide of the required size, as indicated in section 5.

4.3.1 CONNECTION TO THE MAIN POWER

Connect the machine to a **120V** power supply line with **20A circuit breaker** using the cable and socket supplied.

5. INSTALLING/REPLACING THE GUIDE AND THE BIT



Make sure that the system is disconnected from the power supply before carrying out any maintenance or adjustment work.

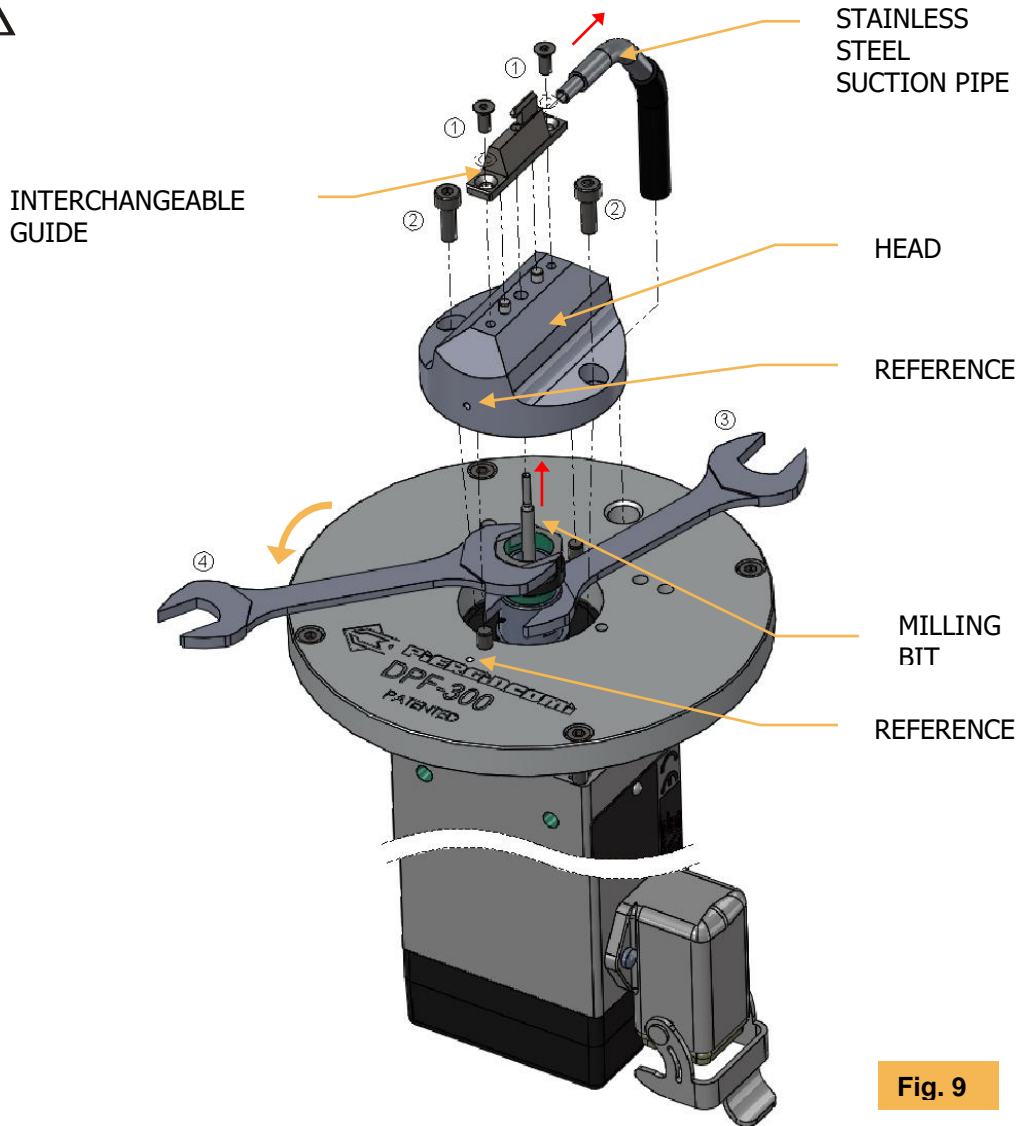

Fig. 9

Before using the machine, check the thickness of the isthmus to be cut and then install the interchangeable guide and milling bit of the required size observing the steps below (Fig.9):

1. Remove the metal suction tube from the guide (when changing a previously installed guide).
2. Loosen the 2 fixing screws **(1)** securing the interchangeable guide.
3. Pull out the interchangeable guide.
4. Loosen the 2 fixing screws securing head **(2)** and remove it.
5. Lock the spindle shaft using the 14mm wrench **(3)** included in the package.
6. Loosen the clamp by turning the 17mm wrench **(4)** included in the package counterclockwise.
7. Remove the milling bit and insert the new one; **Make sure the bit is fully inserted and tightened.**
8. Perform the steps above in reverse making sure to align the reference marks that indicate the correct orientation of the head.

ATTENTION: the diameter of the cutter should **match** the thickness of the guide.

6. USING THE MACHINE



Always wear safety goggles, protective gloves and safety earmuffs when using the machine.

Once the machine has been installed correctly (Section 4) and the appropriate interchangeable guide and bit have been inserted (Section 5), the machine can be operated from the front control panel Fig.10.

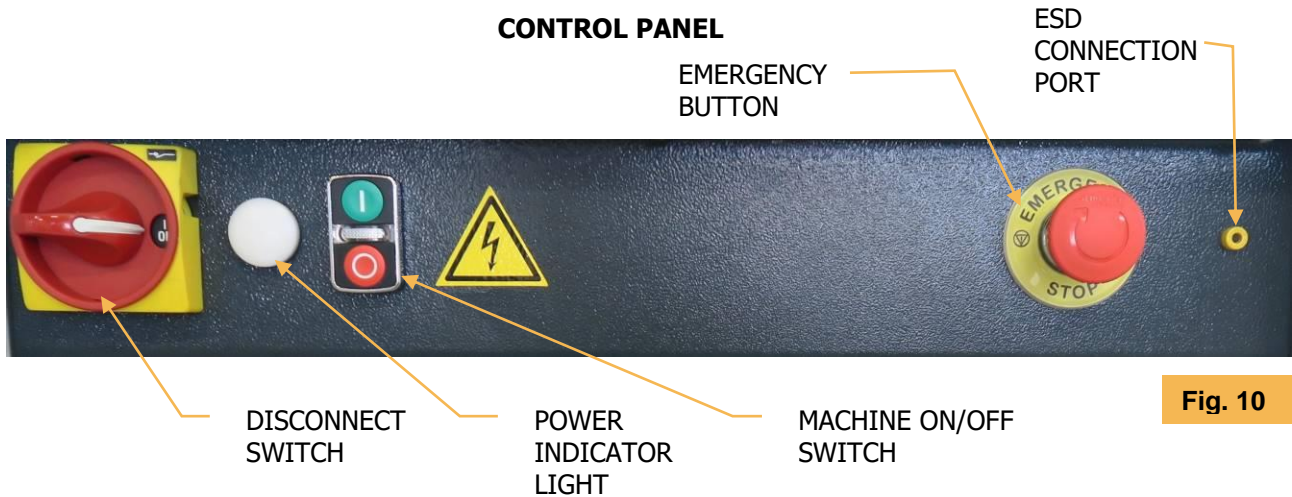

Fig. 10

Switching on the machine Switch on the machine by turning the disconnect switch clockwise (the white power indicator light turns on) and then press the green button **I** on the switch to start the machine (the ORANGE indicator light on the workbench and the switch light turn on).

Switching off the machine Stop the machine by pressing the red button **O** on the switch. Turn the disconnect switch counterclockwise to disconnect the machine from the power grid.



In case of immediate danger, press the EMERGENCY button.



To connect the operator's wristband to the ESD system, use the banana connector on the right.

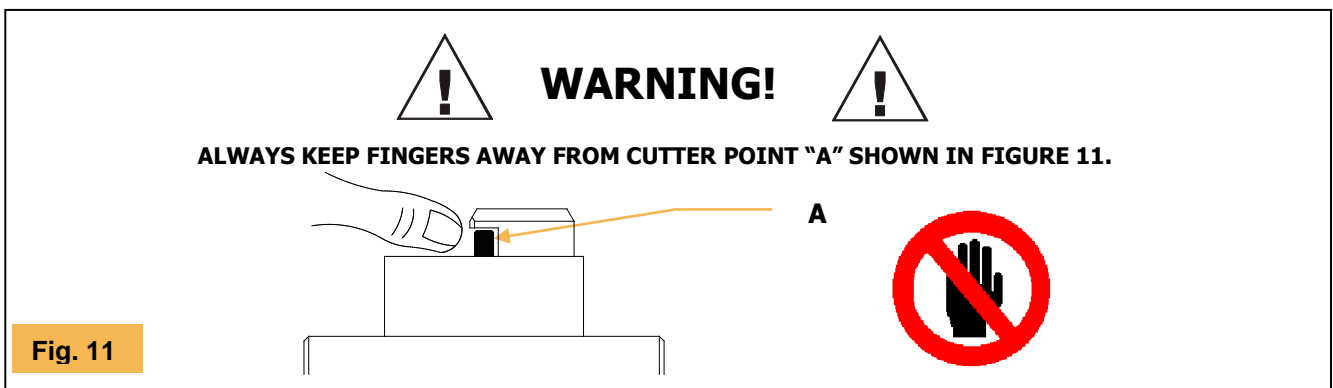

Fig. 11

The operator must acquire a minimum of "practice" in order to use the machine correctly and satisfactorily.

6.1 OPERATIONAL PHASES

The sequence of figures below indicates how to use the machine correctly.

1. Position the slot of the PCB and insert PCB into the guide rail until it rests on the guide.

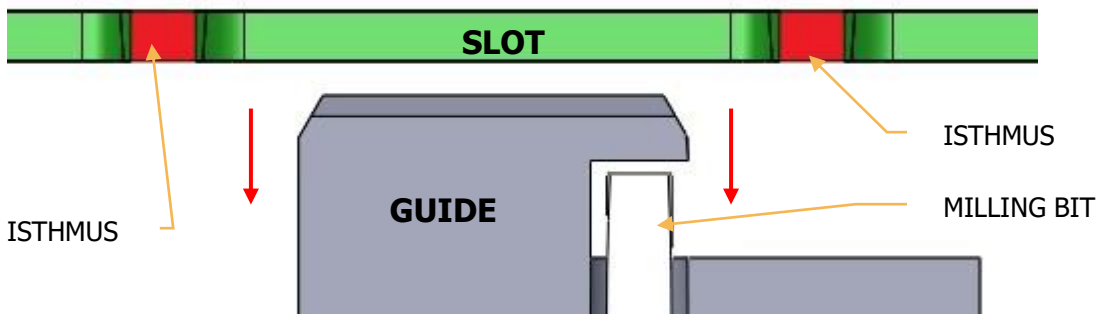

Fig. 12

2. Try to keep the PCB orthogonal to the guide (Fig.15-16). Slide the guide into the slot at an adequate speed, in the direction shown by the arrow until reaching the first isthmus to be removed.



Fig. 13

3. Immediately after cutting the selected isthmus, remove the PCB from the guide and repeat the steps above. Or, if the next isthmus is very close to the one already cut and there is no need to rotate/flip the PCB, slide the guide inside the slot; please note that, in this case, the cutter might remove material from the walls of the slot if the board is not kept perfectly orthogonal to the guide.



Fig. 14

NOTE: Try to hold the PCB in place when cutting the last isthmus to make sure that it does not flip or rotate due to its instability, creating excessive residues.

6.2 PCB ORIENTATION

Figures below indicate the correct orientation of the PCB in relation to the reference axis of the interchangeable guide, for the correct operation of the machine:

CORRECT

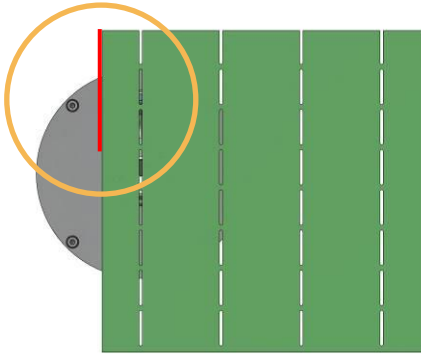

INCORRECT

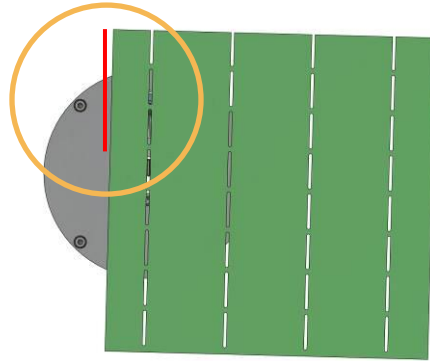
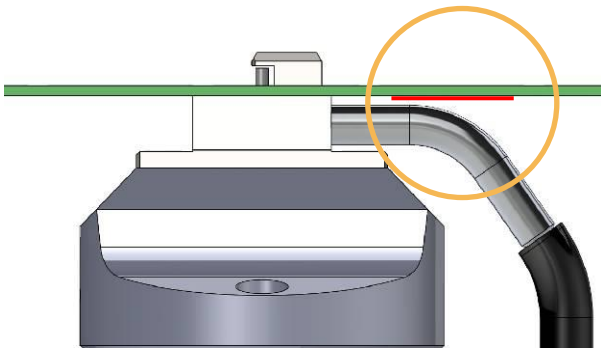

Fig. 15

CORRECT



INCORRECT

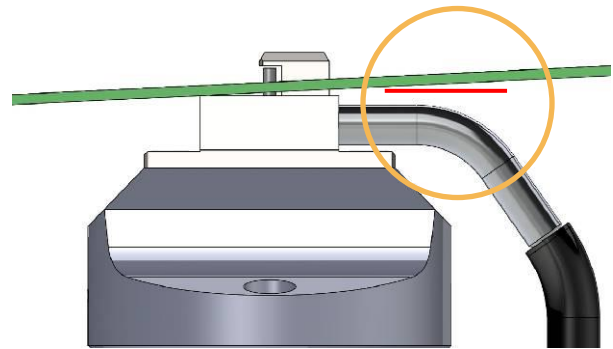

Fig. 16

— Reference axis

7. ENVIROMENTAL IMPACT

The environmental impact of DPF-300 is minimal and has the following main characteristics:

- Dust pollution:*** the machine produces cutting dust that is collected by a special filter provided with a special filter cartridge.
- Oil pollution:*** the machine does not use and, therefore, does not release oil into the environment.
- Noise pollution:*** the machine is equipped with a motor spindle that may generate noise up to 80 dB(A) during cutting, measured at the operator position. The machine is equipped with a suction turbine that generates noise up to 70 dB(A), especially its rear side (that is equipped with a silencer), measured at the operator position.
- Heat pollution:*** the machine features a suction turbine located inside the frame, which generates hot exhaust air that comes out through the back of the turbine (equipped with a silencer); also, the turbine surfaces are subject to overheating and may reach temperatures of up to 55°C.

8. WIRING DIAGRAM

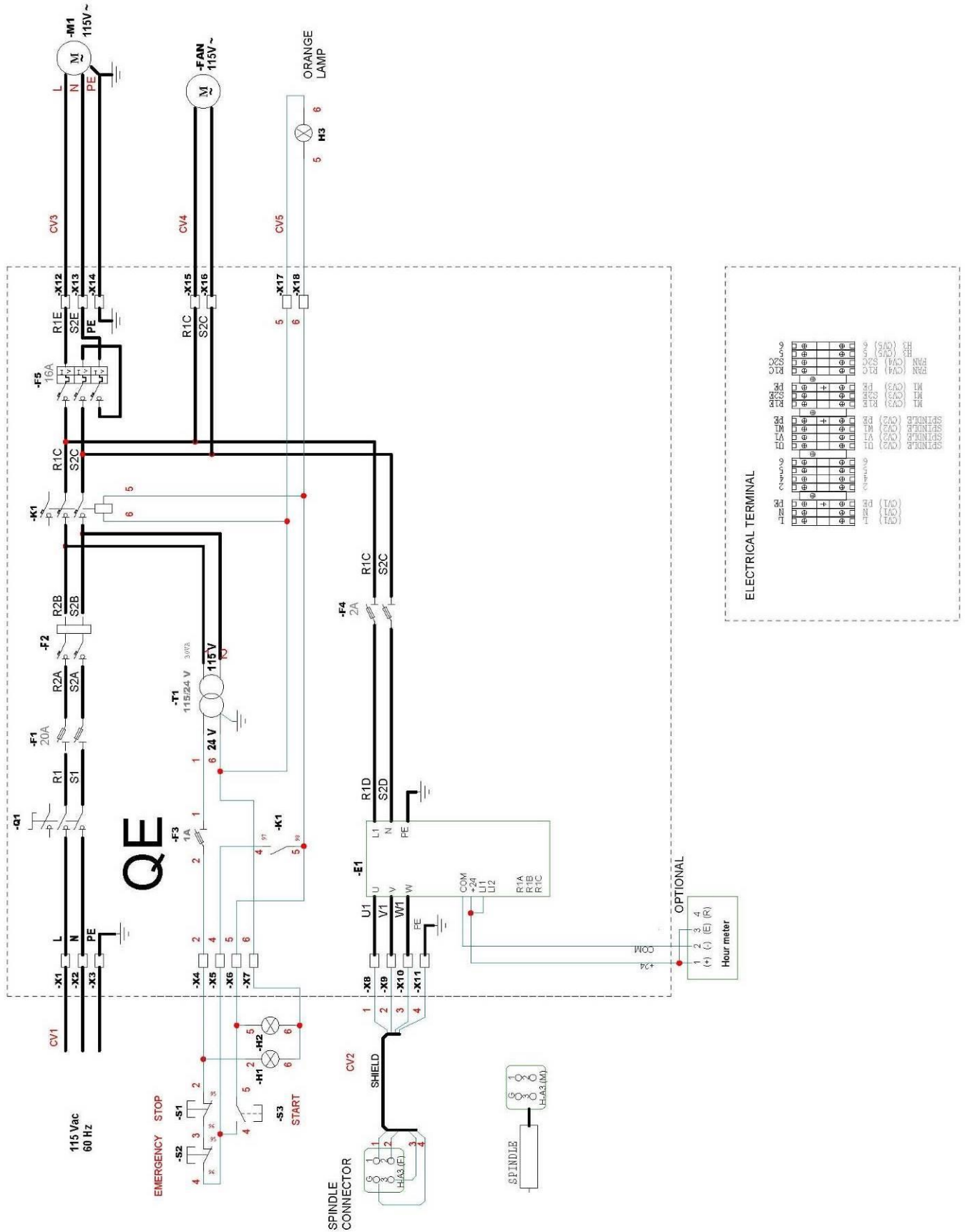

9. MACHINE MAINTENANCE



Make sure that the system is disconnected from the power supply before carrying out any maintenance or adjustment work.

The machine is designed to allow easy maintenance; therefore, the electrical panel can be accessed from the front of the machine, via the protective casing that consists of a hinged door secured with the 3 screws indicated by the arrows (Fig.17). The motor spindle mount can also be accessed by removing the protective casing indicated in section 9.3.



Fig. 17

Remove the 4 screws from the machine back casing to access the compartment that houses the motor, the extraction system and the motor spindle compartment cooling fan.



Fig. 18

9.1 ROUTINE MAINTENANCE

DAILY:

- General machine cleaning:
- Check the level of dust inside the filter and the clogging of the filter cartridge.
- Check the wear of the milling bit.
- Check the wear of the interchangeable guide.
- Check the wear of the suction tube

N.B.: Do not clean the ESD workbench with alcohol-based detergents.
Do not use liquid detergents to clean the motor spindle

PERIODICALLY (every 20-30 days):



Always wear a dust mask and protective gloves.



- Check the locking screws.
- Clean the rear exhaust silencer with compressed air.
- Clean the top of the motor spindle with compressed air after removing the aluminium head that secures the guide in place (see section.5).

9.1.2 SPARE PARTS

- Interchangeable guide standard thickness 1.5-2.5 mm. P/N DPF-GI-X.X
- FR4 milling bit (10pc. Pack) available standard diameters 1.5-2.5 mm. P/N DPF-FF-X.X
- ALUMINIUM milling bit (10pc. Pack) standard available 1.5-2.5 mm. P/N DPF-FA-X.X
- Motor spindle with centring kit P/N DPF-300-TF-000
- Filter cartridge for 1-1/4" filter P/N DPF-CAR-3.0
- Suction kit with regulator P/N DPF-21192-41489
- Suction hose Ø10 P/N DPF-PVCRTAGE010
- Black antistatic hose Ø8 P/N DPF-TAV0806B
- Stainless steel suction tube P/N DPF-TF-005

Custom interchangeable guides available upon request.

9.2 DUST FILTER CLEANING



Always wear a dust mask and protective gloves when opening and cleaning the dust container.

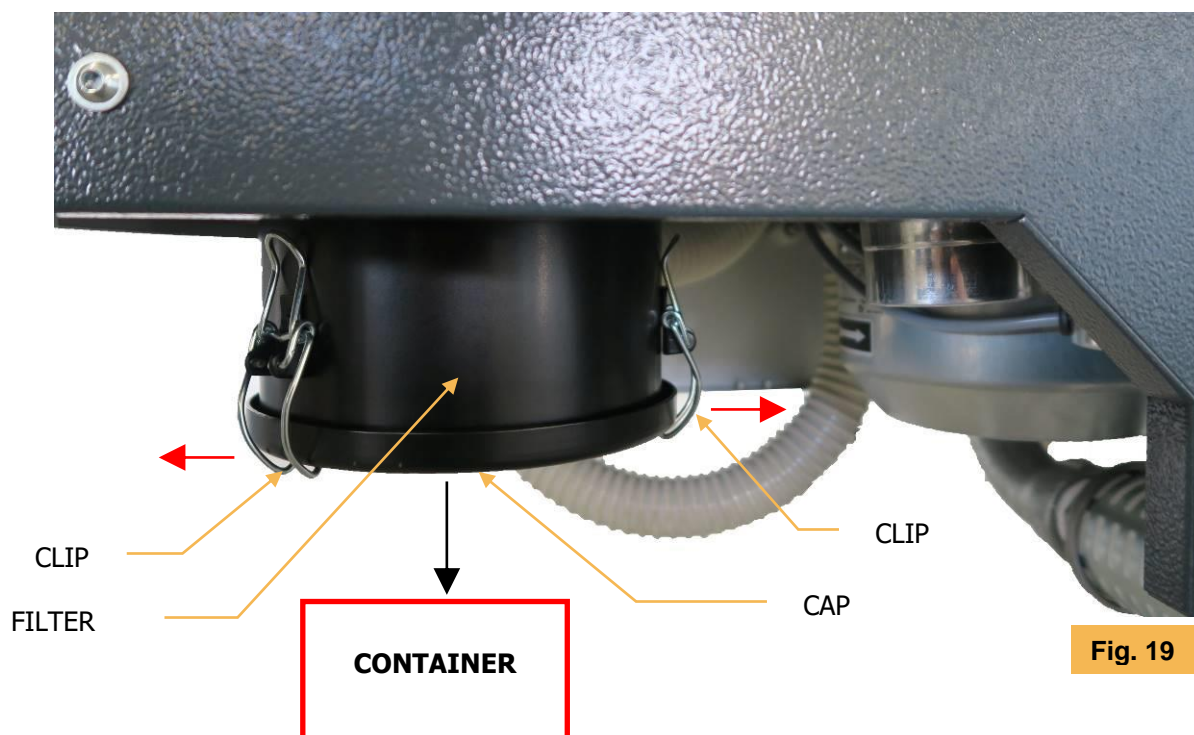

Fig. 19

The dust filter is located under the frame's rear compartment; it is suitably built and features a filter cartridge that complies with standard EN 60335-269 and can be easily accessed thanks to its special opening system.

To empty the dust filter, proceed as follows (Fig.19):

1. Place a container under filter to collect the dust;
2. Open the filter cap using the 3 clips around it;
3. Clean the filter cartridge with compressed air and remove any dust residues.
This operation must be carried out in a dedicated room;
4. Perform the steps above in reverse.

After performing step 3, if the filter cartridge is still clogged with dust, replace it with a new one (contact the technical support service).

NOTE: If the machine is left running with a very clogged filter for long periods of time, the extraction system will become inefficient and, most importantly, the motor will overheat and may break down prematurely.

ATTENTION: Check the **level** of dust inside the filter constantly and make sure that the filter cartridge is not clogged with dust.

9.3 MOTOR SPINDLE MAINTENANCE



Make sure that the system is disconnected from the power supply before carrying out any maintenance or adjustment work.

To access the motor spindle, open the electrical panel following the instructions in chap.9. Then remove the 4 screws shown in Fig.20, that secure the protective casing, to access the motor spindle mount.

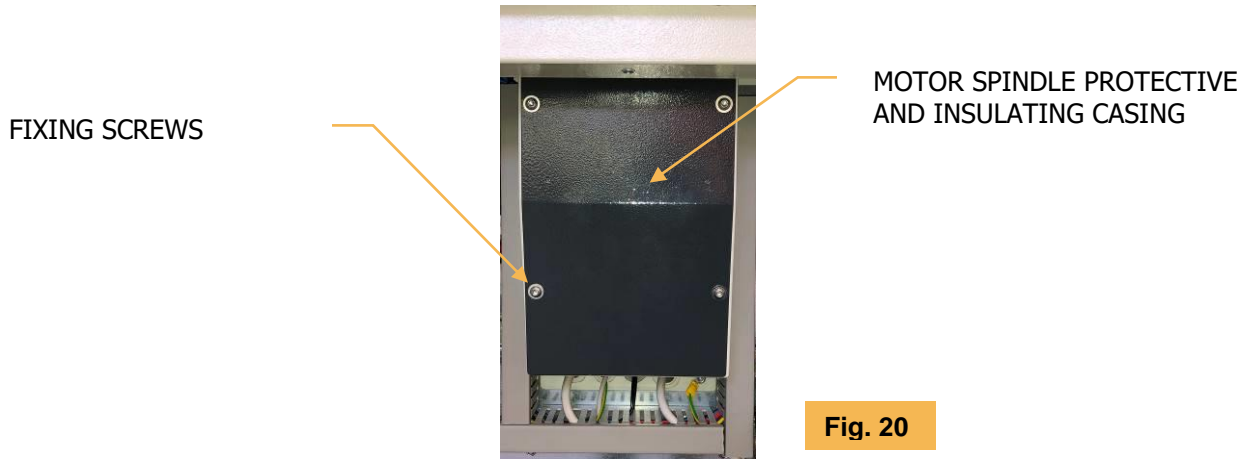

- DO NOT LOOSEN THE SCREWS ON THE MOTOR SPINDLE MOUNT (Fig.21)

CAUTION: Any accidental tampering with the mount screws will require a new alignment of the INTERCHANGEABLE GUIDE-CUTTER assembly.

For any motor spindle fault, please contact our technical support department to better assess the problem encountered and determine whether the part must be overhauled or replaced.

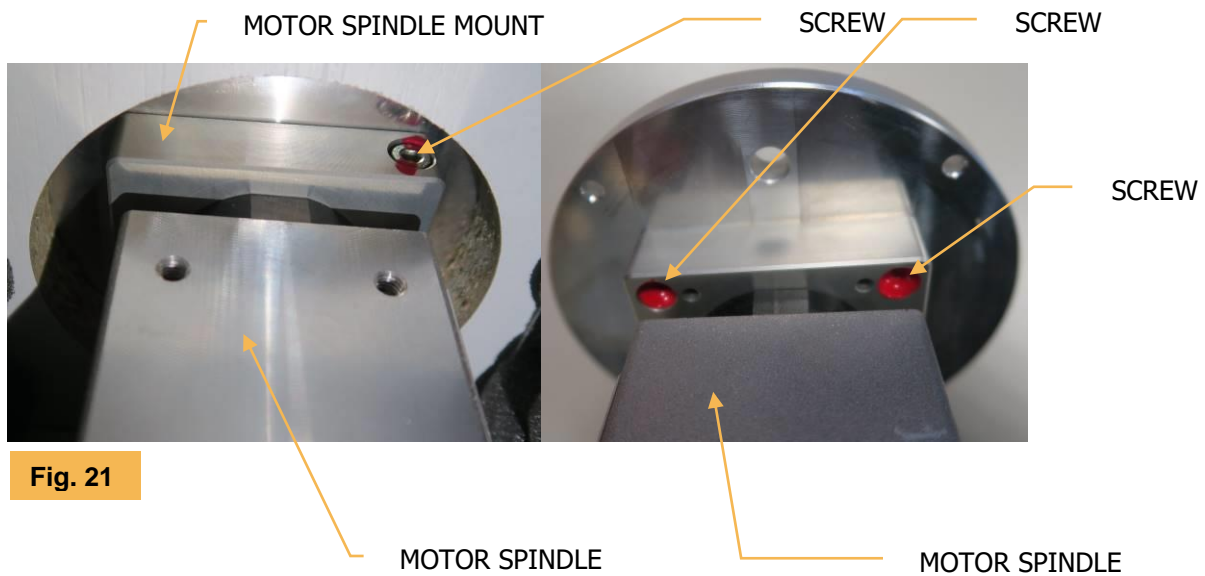

10. TECHNICAL SPECIFICATIONS

10.1 GENERAL CHARACTERISTICS

Approx. dimensions	64 cm (W) x 70 cm (L) x 95 cm (H)
Clearance	164 cm (W) x 170 cm (L)
Interchangeable guide material	Hardened ground steel
Interchangeable guide thickness	Standard 1.5 – 2.5 mm
Cutter diameter	Standard 1.5 – 2.5 mm
Motor spindle power	0.27 kW
Motor spindle speed	24,000 revolutions/min
Storage temperature	from -10°C to +50°C
Non-operating temperature	from 0°C to +50°C
Operating temperature	from 10°C to +35°C
Sound pressure	80 dB(A) ±3 dB(A) measured at the operator position
Vibrations	Test FR4 thck.1.6 mm / cutter 2 mm < 2.5 m/s ² Test FR4 thck.1.6 mm / cutter 2 mm
Weight	73 kg
Voltage	115V/60Hz
Input power	1 kW
Socket	115V 2P+T
Vacuum	30 kPa (300 mbar)
Suction Filter	1-1/4" connection
CE Marking	

10.2 CHARACTERISTICS OF THE PCBs TO BE SEPARATED

PCB thickness	Max. 4.0 mm
Slot length (L)	Min. 11 mm
Slot width (V)	standard 1.5 - 2.5 mm
Slot width tolerance:	0 / - 0.02 mm
Isthmus distance form components (C)	Min. 0.8 mm
PCB Material	FR4 – CEM – CCL – ALUMINIUM*

*For aluminium PCBs, please contact American Hakko for the corresponding mill bit.

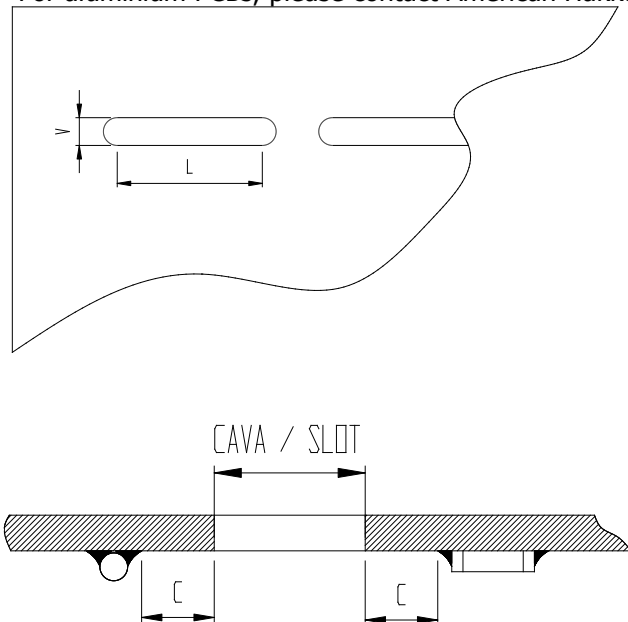

Fig. 22

11. WARRANTY CONDITIONS

American Hakko Products, Inc. warrants that CHP DPF-300 will be free from defects in material and workmanship for a period of ninety (90) days from the date of purchase, with extended warranty on electronic portion of the unit, provided that no warranty shall apply to products that have been damaged, altered, abused, improperly installed, improperly maintained, repaired after purchase, or have had their identification markings removed or altered in any way. No warranty shall apply to any product or component part that is subject to normal wear during use (such as tips, nozzle, blades, fuses, metal parts, filters, brushes, and the like). All warranties are not transferable.

Extended warranty may apply to certain portion of DPF-300. For details on product warranty policy from American Hakko Products, Inc. Visit www.HakkoUSA.com.

12. TECHNICAL SUPPORT

American Hakko Products, Inc.

28920 Avenue Williams, Valencia, CA 91355

Tel : (661)294-0090 Fax: (661)294-0096

Toll Free : (800)88-HAKKO(42556)

<http://www.HakkoUSA.com> E-mail : Support@HakkoUSA.com

DPF-300 DECLARATION OF CONFORMITY

MANUFACTURER: **American Hakko Products, Inc.**
28920 Avenue Williams, Valencia, CA 91355

MACHINE DESCRIPTION: **DPF-300**
Milling machine with electric extraction system for
PCB separation

THE **DPF-300** COMPLIES WITH THE ESSENTIAL REQUIREMENTS of the following
(harmonized) standards:

DIRECTIVE 2006/42/CE

- UNI EN ISO 12100** Safety of Machinery - General principles for design - Risk assessment and risk reduction.
- UNI EN ISO 13857** Safety of machinery - Safety distances to prevent hazard zones being reached by upper and lower limbs.
- UNI EN ISO 14120** Safety of machinery - Guards - General requirements for the design and construction of fixed and movable guards
- UNI EN ISO 13849-1** Safety of machinery - Safety-related parts of control systems - Part 1: General principles for design.
- EN 60204-1** Safety of machinery Electrical equipment of machines. Part 1: General requirements.
- IEC EN 61340-5-1** Protection of electronic devices from electrostatic phenomena - General requirements
- DIN EN 60335-2-69** (ex BIA ZH 1/487) Safety of household and similar electrical appliances - Part 2: Particular requirements for wet and dry vacuum cleaners, including power brush, for industrial and commercial use.

DIRECTIVE 2014/30/UE EMC (Electromagnetic compatibility)

- EN 61000-6-4** Part 6-4: Generic standards - Emission standard for industrial environments.
- EN 61000-6-2** Part 6-2: Generic standards - immunity for industrial environments.

DIRECTIVE 2014/35/UE (Low Voltage)

All electrical materials and subsystems used in the construction of the DPF-300 machine comply with Directive 2014/35 /UE.

July 15th, 2020

