

## SOLDER FEED UNIT

### FU-500

#### Instruction Manual



Thank you for purchasing the HAKKO FU-500 solder feed unit.  
Please read this manual before operating the HAKKO FU-500.  
Keep this manual readily accessible for reference.



#### TABLE OF CONTENTS

1. PACKING LIST.....	1
2. SPECIFICATIONS .....	1
3. WARNINGS, CAUTIONS AND NOTES.....	2
4. PART NAMES.....	3
5. INITIAL SETUP.....	5
6. OPERATION .....	7
7. MAINTENANCE .....	18
8. ERROR MESSAGES .....	19
9. TROUBLE SHOOTING GUIDE .....	21
10. EXPLODED VIEW.....	22
11. PARTS LIST.....	23

# 1. PACKING LIST

Please check to make sure that all items listed below are included in the package.

HAKKO FU-500 .....	1	Feeder cable (5m) .....	1
Feeder unit (Type L or straight) .....	1	Power cord (for HAKKO FU-500) .....	1
Tube unit (for $\phi 0.3$ to 1.0 mm) .....	1	Instruction manual .....	1
Tube unit (for $\phi 1.2$ to 1.6 mm) .....	1		
Solder reel stand .....	1		

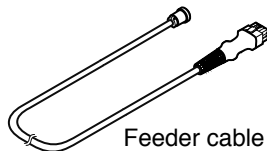
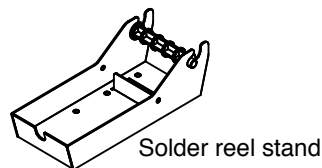
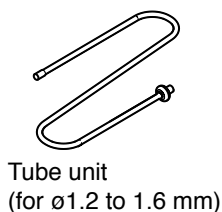
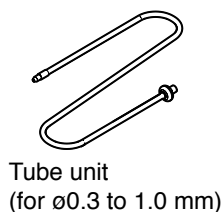
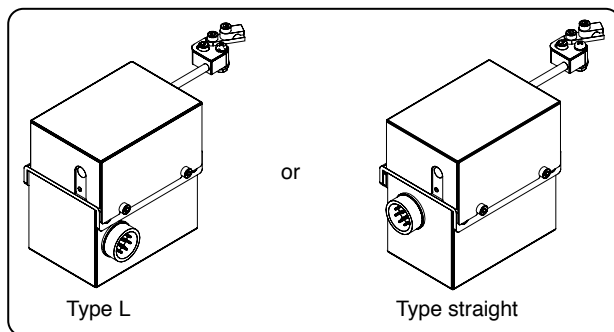
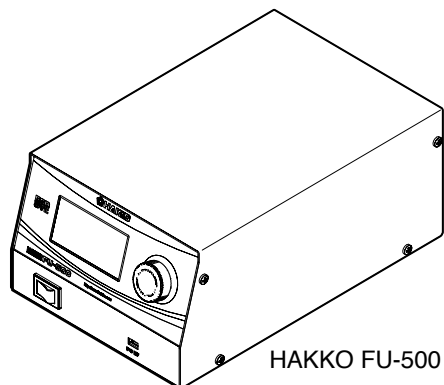

\*Solder feed pulley unit  
Solder feed guide set  
Teflon tube are optionally available.  
(See 11. Part List in page 23)

# 2. SPECIFICATION

## ●HAKKO FU-500 (Station only)

Power consumption	35W
Dimensions (W x H x D)	145(W)x100(H)x230(D)mm (5.7 x 3.9 x 9.1 in.)
Weight	2.3kg (5.1 lb.)

## ●Feeder unit

Model number (Compatible solder diameter)	( $\phi 0.3 - 1.6$ mm)
Weight*	800 g

\*With the solder feed pulley unit, the solder feed guide set and the teflon tube

## ●Solder diameter

For the HAKKO FU-500, the compatible solder wire size varies by model number.  
Please check the model number of your product before ordering corresponding parts according to the Part List on page 23.

The solder diameter that can be used with the HAKKO FU-500 are shown in the table below.  
Before changing the solder diameter, see "● How to change the solder diameter" on page 17.

Solder diameter (mm)	0.3	0.5	0.6(0.65)	0.8	1.0	1.2	1.6
----------------------	-----	-----	-----------	-----	-----	-----	-----

Up to 1kg bobbin of solder can be used.

---

※This product is protected against electrostatic discharge.  
※Specifications and design are subject to change without notice.

■ **Electrostatic Protection**

This product includes such features as electrically conductive plastic parts and grounding of the unit as measures to protect the device to be soldered from the effects of static electricity. Be sure to observe the following instructions:

1. When making repairs or replacing parts, take sufficient care not to expose live electrical parts or damage insulation materials.
2. Be sure to ground the unit during use.

---

## 3. WARNINGS, CAUTIONS AND NOTES

---

Warnings and cautions are placed at critical points in this manual to direct the operator's attention to significant items. They are defined as follows:

 **WARNING** : Failure to comply with a WARNING may result in serious injury or death.

 **CAUTION** : Failure to comply with a CAUTION may result in injury to the operator, or damage to the items involved. Two examples are given below.

 <b>WARNING</b>
--

- |   |
|---|
| <ul style="list-style-type: none"><li>● Turn the power off when not in use, or left unattended.</li><li>● This appliance is not intended for use by persons (including children) with reduced physical, sensory or mental capabilities, or lack of experience and knowledge, unless they have been given supervision or instruction concerning use of the appliance by a person responsible for their safety.</li><li>● Children should be supervised to ensure that they do not play with the appliance.</li></ul> |
|---|

● To prevent accidents or damage to the HAKKO FU-500, be sure to observe the following.

 <b>CAUTION</b>
--

- |  |
|--|
| <ul style="list-style-type: none"><li>● The cutting blade is sharp. Be careful not to cut your fingers.</li><li>● When resin core solder that has been cut is not used, the properties of the resin (flux) may deteriorate with time.</li><li>● Once the solder has been cut and is inside the guide pipe, the heat from the soldering iron may accelerate the deterioration of the resin (flux). Use solder that is inside the guide pipe as soon as possible.</li><li>● Do not damage the guide pipe by bending or twisting it.</li><li>● Do not allow the tube to be bent at a severe angle. Otherwise, it will become clogged with solder.</li><li>● Keep the cutting blade and pulley clean of solder and flux using a brush or other suitable cleaning device.</li><li>● Periodically remove the guide pipe or the teflon tube and clean off any accumulated flux.</li></ul> |
|--|

# 4. PART NAMES

## ● HAKKO FU-500

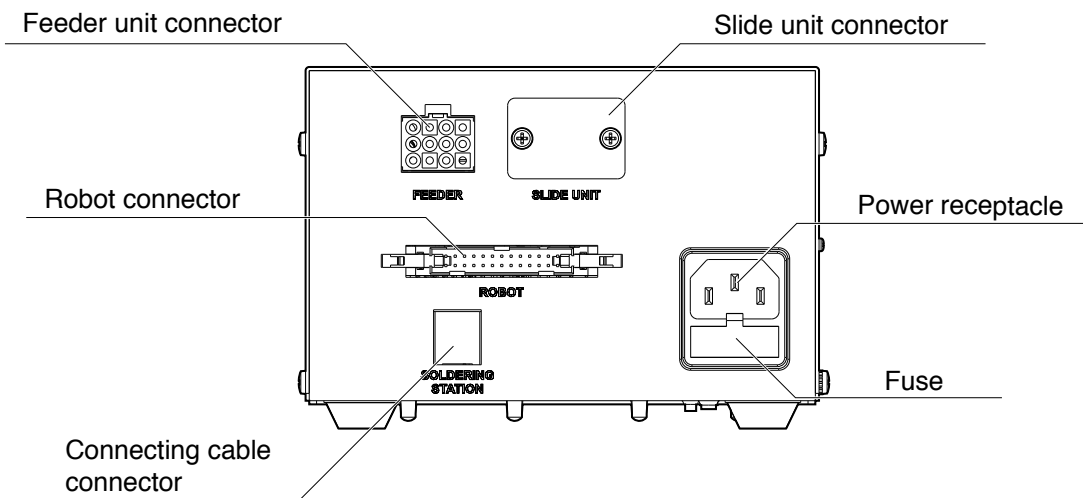
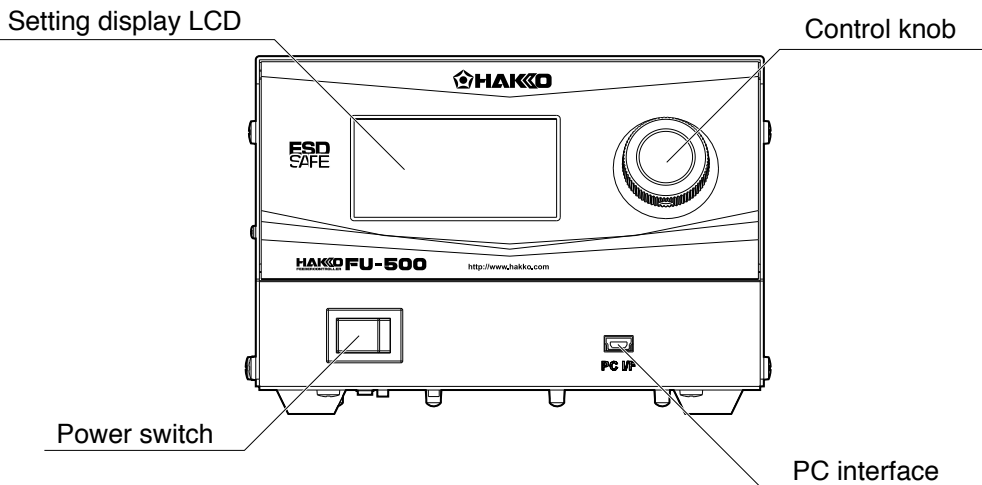

## ● Feeder Unit

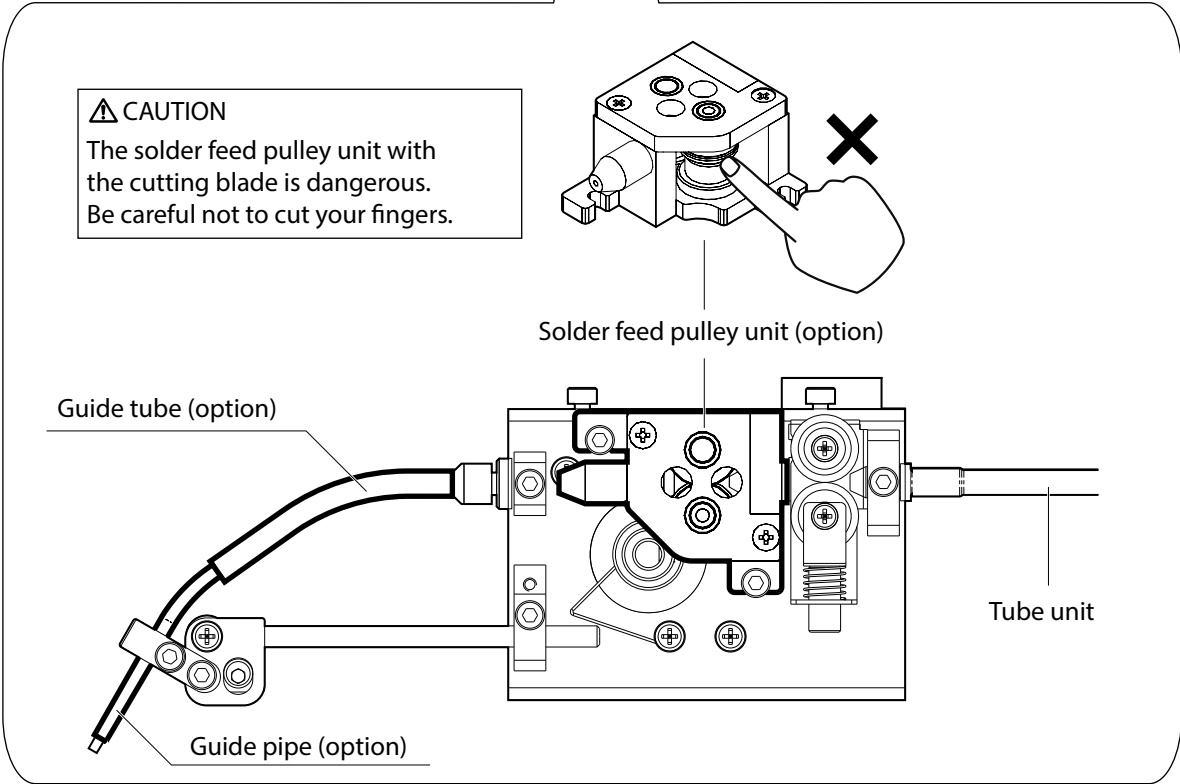
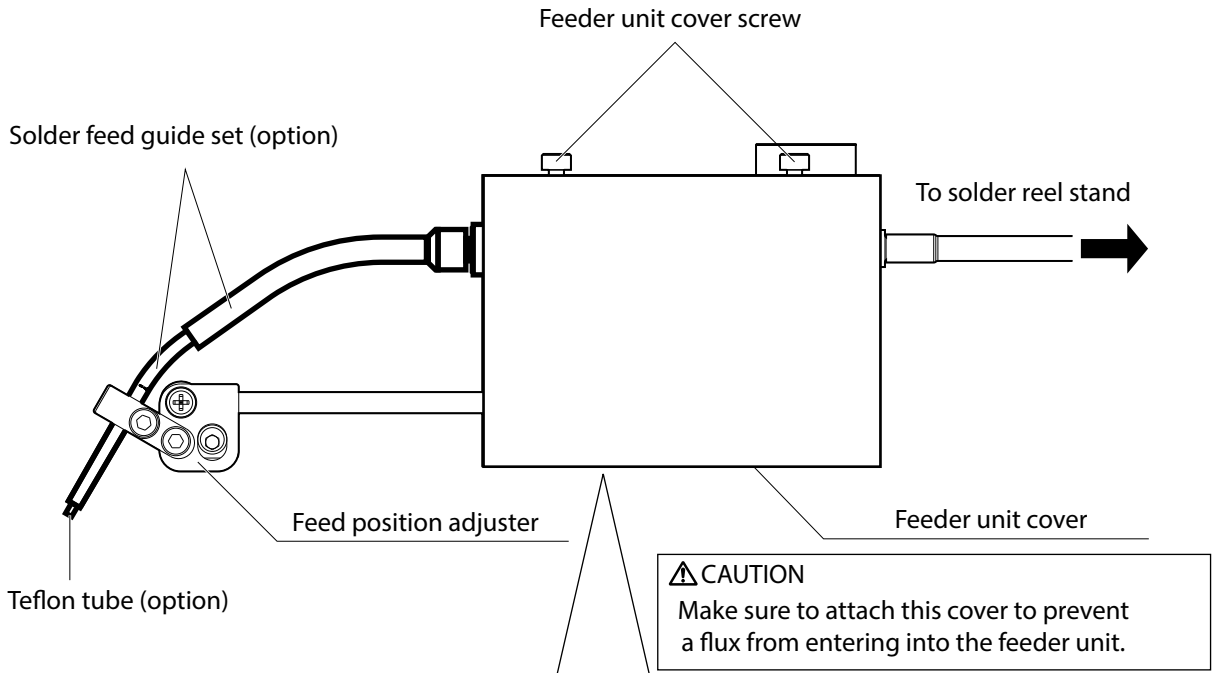

# 5. INITIAL SETUP

Use a hex wrench of 2.5 mm.

## Connecting components

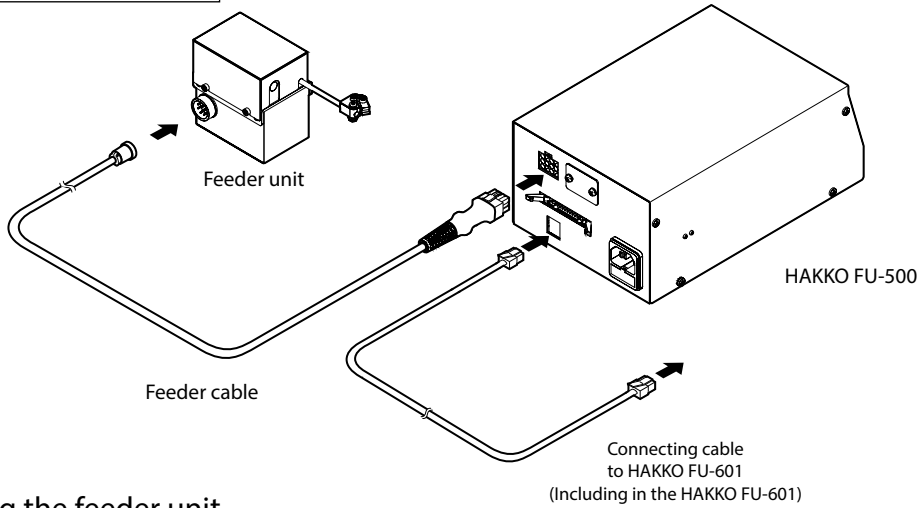

### ● Assembling the feeder unit

Install the tube unit, the solder feed pulley unit, the solder feed guide set and the teflon tube. Tighten the screws shown in the figure below. Draw solder through the tube unit and supply to the feeder unit.

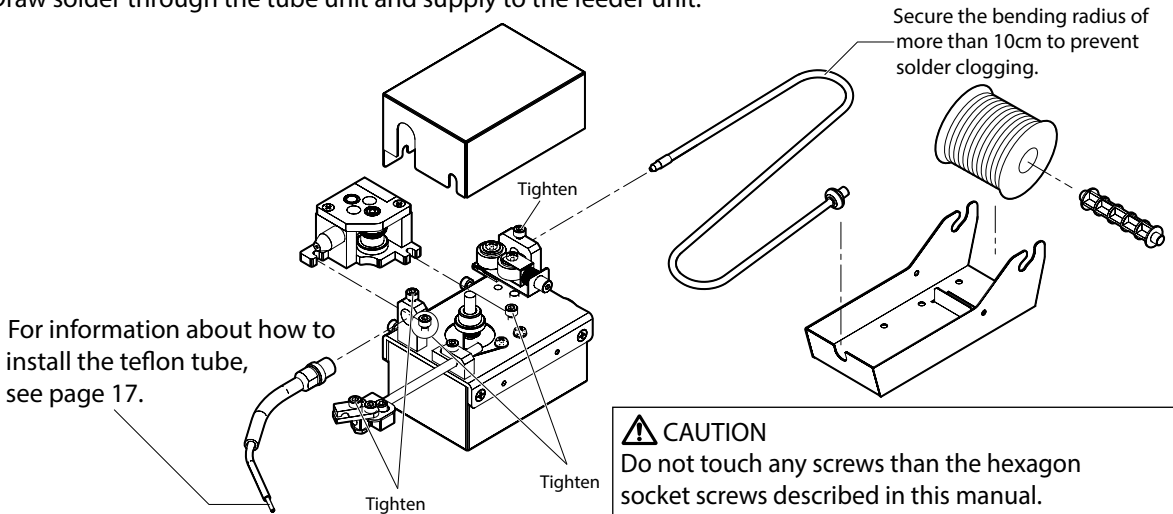

**⚠ CAUTION**  
Do not touch any screws than the hexagon socket screws described in this manual. The attachment of the solder feed pulley unit for  $\phi 0.3\text{mm}$  (BX1000) is different. Refer to the "How to set solder" in the BX1000. Please be careful not to tighten the screw too much.

### How to set solder

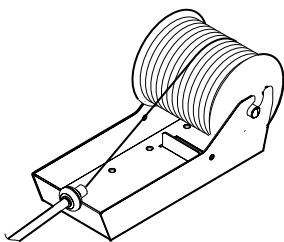

Ensure that solder is reeled out of the top of the bobbin.

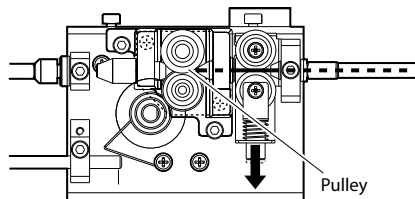

Draw solder through the tube unit and press the end of solder against the pulley of the solder feed pulley unit. With this condition, start the HAKKO FU-500 to feed solder until solder comes out of the end of the teflon tube.

## ● Adjusting the solder feed position

1. Loosening the adjustment screw ① will allow you to move the entire solder feed guide set as shown in the figure below. Move the solder feed guide set to the tip.

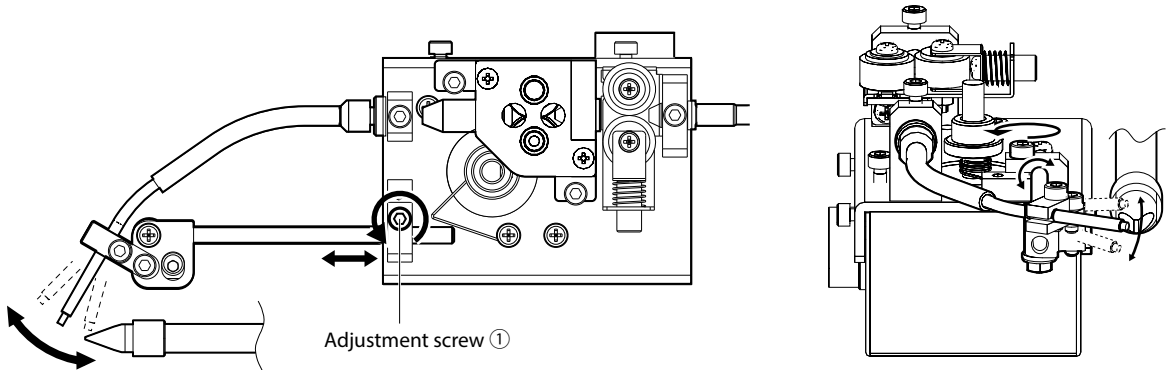

2. Loosening the adjustment screw ② will allow you to move the guide pipe as shown in the figure below. Move the guide pipe until solder comes into contact with the tip.

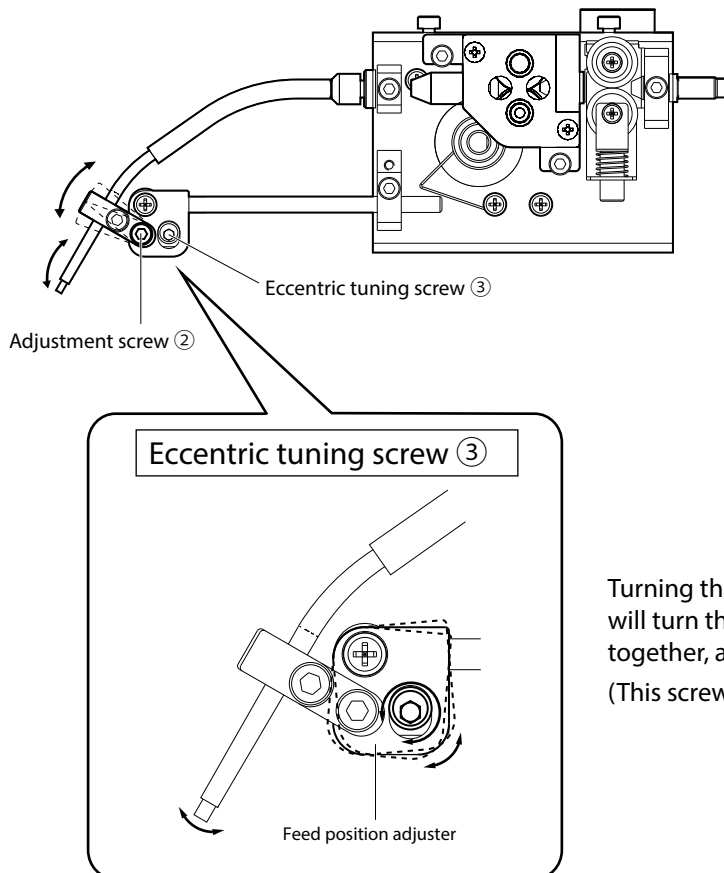

Turning the eccentric tuning screw ③ will turn the feed position adjuster together, allowing you to make tuning. (This screw cannot be removed.)

# 6. OPERATION

## Auto mode

In auto mode, the unit operates according to commands from the robot.  
 There are two types of auto mode: PS and DS.  
 For more information, see the timing chart below:

### · PS (Point soldering) mode

Point soldering process

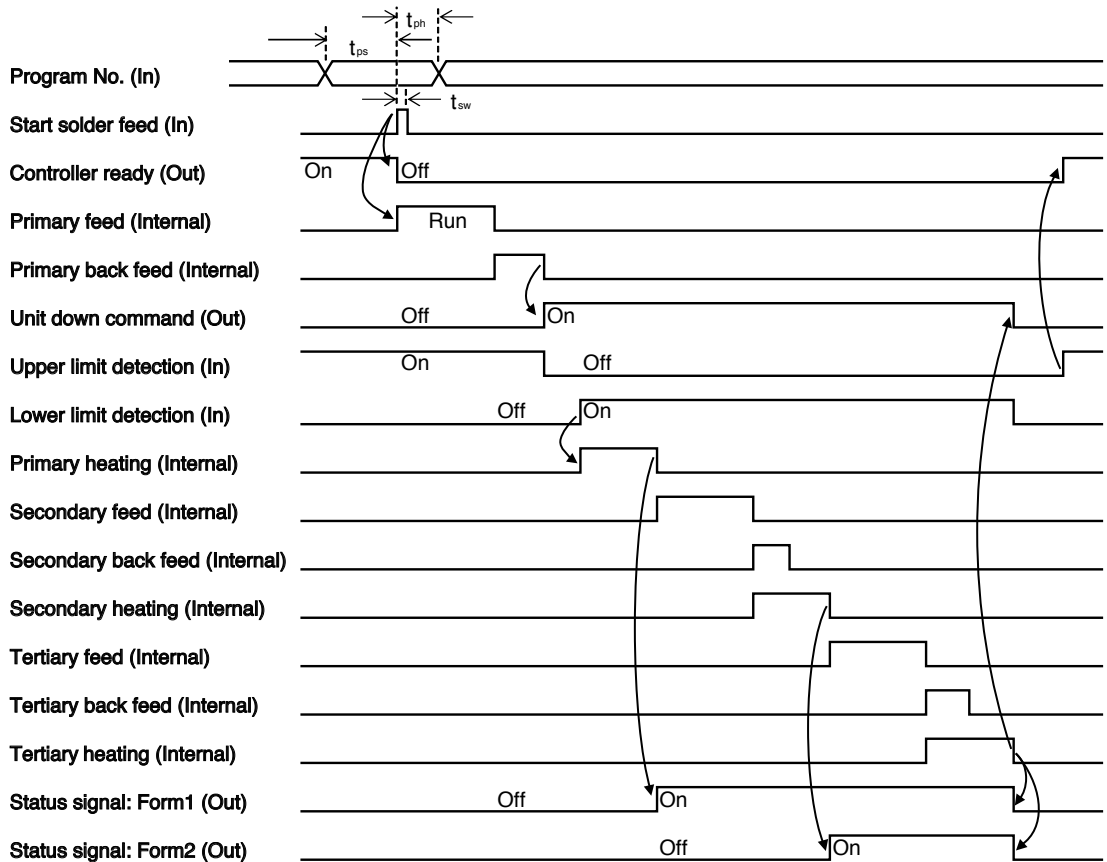

- \* When selecting a program number, set the signal P7 (MSB) to 0 (zero).
- \* The controller outputs either the status signal Form1 or Form2 (according to the setting made during program setting).

Program selection setup time :  $t_{ps} > 5\text{msec}$   
 Program selection hold time :  $t_{ph} > 25\text{msec}$   
 Start signal pulse width :  $t_{sw} > 25\text{msec}$



## DS (Drag Soldering) Mode

Drag soldering process

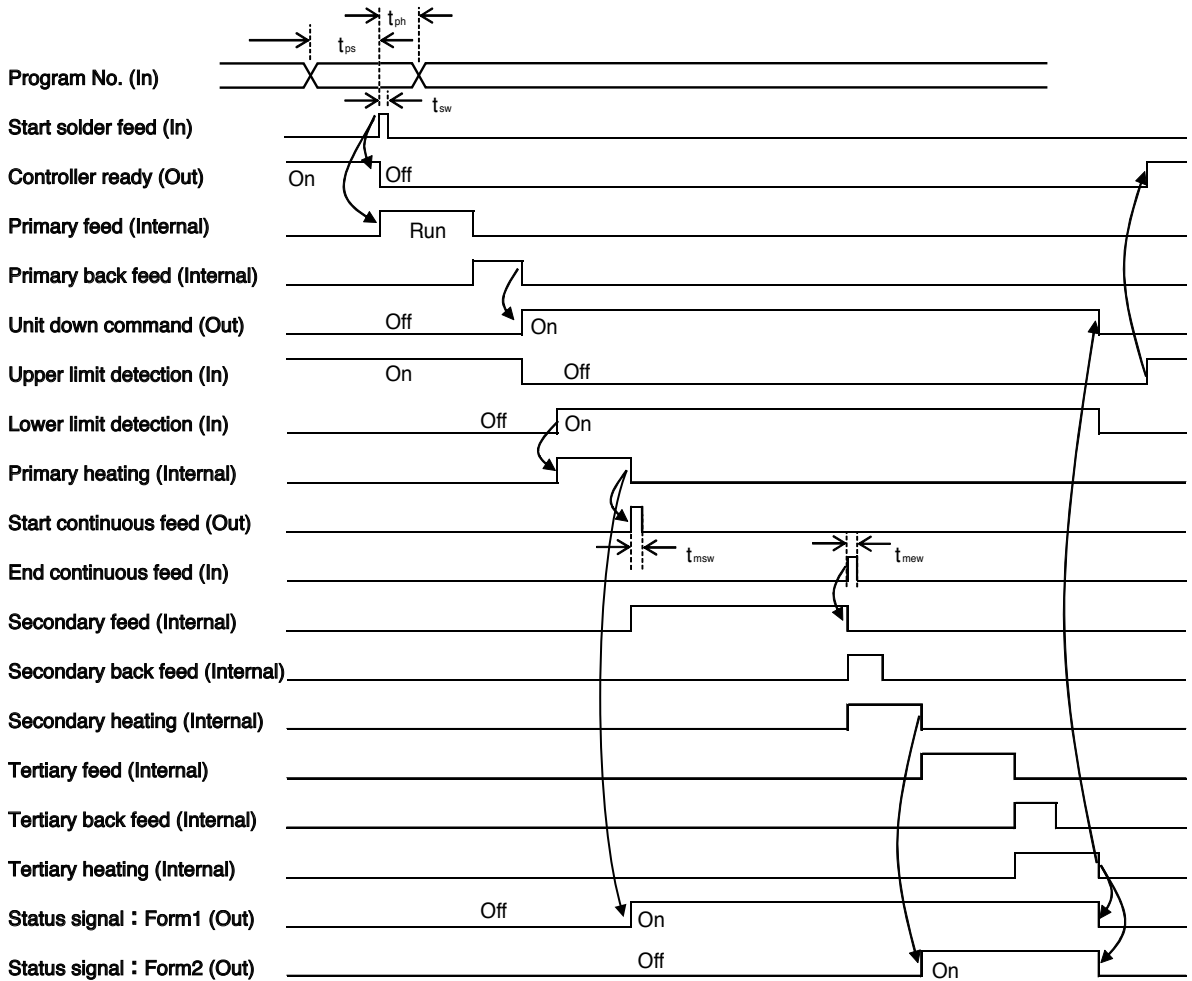

- \* When selecting a program number, set the signal P7 (MSB) to 1.
- \* The controller outputs either the status signal Form1 or Form2 (according to the setting made during program setting).

Program selection setup time :  $t_{ps} > 5\text{msec}$   
 Program selection hold time :  $t_{ph} > 25\text{msec}$   
 Start signal pulse width :  $t_{sw} > 25\text{msec}$   
 Iron move signal pulse width :  $t_{msw} > 25\text{msec}$   
 Iron stop signal pulse width :  $t_{mew} > 25\text{msec}$

## Robot I/F pin assignment

2.54 mm pitch 26-pin ribbon cable connector

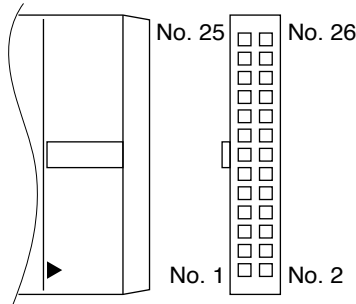

HAKKO FU-500 back

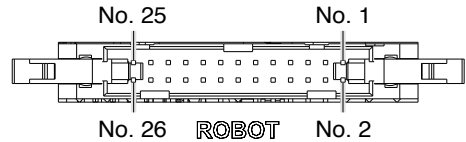

Pin No.	Signal name	I/O	Function
1	P0	In	Program No. LSB
2	P1	In	Program No.
3	P2	In	Program No.
4	P3	In	Program No.
5	P4	In	Program No.
6	P5	In	Program No.
7	P6	In	Program No.
8	P7	In	Program No. MSB
9	Start	In	Start solder feed
10	Low_Lim	In	Bottom limit detection
11	Up_Lim	In	Top limit detection
12	Move_End	In	End continuous feed
13	Emergency	In	Emergency stop
14	Ready	Out	Controller ready
15	Down	Out	Unit down command
16	Move_Start	Out	Start continuous feed
17	Feeder_Error	Out	Feeder controller error output
18	Iron_Ctrl_Status	Out	HAKKO FU-601 status output (Error or Ready)
19	Status	Out	Status signal
20	NC		
21	NC		
22	NC		
23	IO_Vsup	In	I/O power input (24V recommended)
24	DC24V_OUT	Out	24V output
25	IO_GND		I/O GND
26	IO_GND		I/O GND

1) The program No. MSB (P7) is used to select point or drag soldering.

OFF : Point soldering mode

ON : Drag soldering mode

2) Top\_Lim and Bot\_Lim signals are ignored when the slide unit connection mode is selected to internal mode.

3) Down signal is not output when the slide unit connection mode is selected to internal mode.

4) DC24V output voltage is turned ON/OFF by interlocking with the ON/OFF state of the power switch.

## Robot I/F input and output circuits

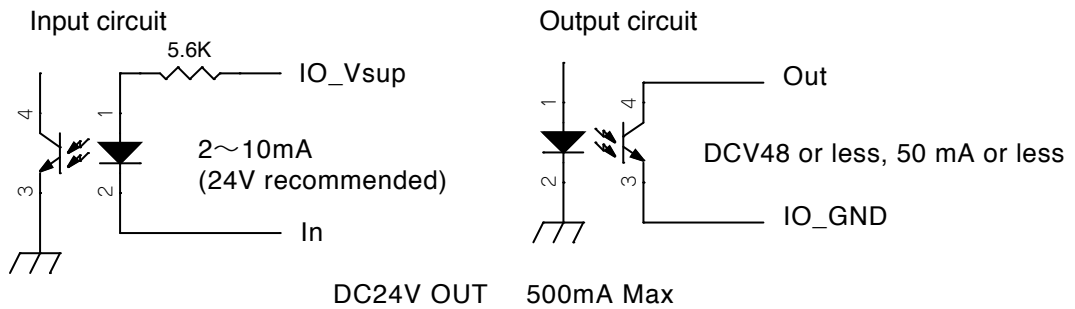

## HAKKO FU-601 I/F

Connecting cable (6-pole 6-core modular cable)

Pin No.	Signal name	I/O	Function
1	RxD	In	Incoming data
2	TxD	Out	Outgoing data
3	Iron_Ready	In	HAKKO FU-601 Ready signal
4	Iron_GND		HAKKO FU-601 GND
5	Iron_GND		
6	Iron_Vcc	In	HAKKO FU-601 Vcc (5V)

It transfers status and data to and from the HAKKO FU-601.

## PC I/F : USB Mini-B

The PC I/F establishes communications with PC to send and receive various information. It is operated on a virtual COM port.

Please install the driver (freeware) to your PC from the following URL:



<http://www.cypress.com/?rID=63794>

From the top page, proceed as follows:

(Support > Software Tools > Software and Drivers > Microsoft Certified USB UART Driver)

### 1) Uploading/downloading programs

The PC I/F writes (downloads) programs created in the PC to the controller or reads in and uploads programs to the PC.

### 2) Uploading/downloading the HAKKO FU-601 setting information

The PC I/F uploads or downloads the set temperature, the offset temperature and the preset temperature of the HAKKO FU-601.

3) Uploading the HAKKO FU-601 tip temperature

The PC I/F reads in the iron tip temperature from the HAKKO FU-601 and uploads it to the PC.

4) Uploading the operation log

The PC I/F uploads the total number of soldering points and the total amount of fed solder to the PC.

5) Clearing the operation log.

The PC I/F clears the operation log.

The PC I/F does not operate while the feeder is run except for uploading of the tip temperature. The display for uploading of the tip temperature is not updated while the feeder is run. For more information about how to use, see the HAKKO FU-500 PC Link Software Instruction Manual.

The PC Link Software can be downloaded from the HAKKO Document Portal after user registration.



<https://doc.hakko.com>

**Changing the settings**

Turn on the power switch of HAKKO FU-500.

The start-up screen will be displayed, and then move to Auto Mode Standby screen.

If the HAKKO FU-500 receives a Start signal when this screen is displayed, it will start to operate for Auto Mode.

If the HAKKO FU-500 does not receive a Start signal and the control button is pressed, it will show the Mode Select screen.

To change the value or the cursor position, turn the control knob and then press the knob to confirm.

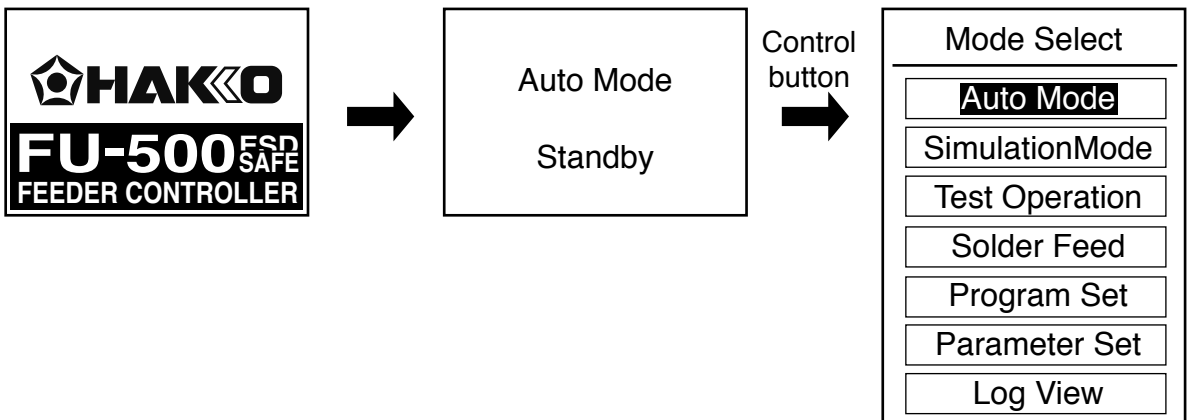

(3 lines are displayed at a time.)

## ●Selecting Auto Mode

When you select Auto Mode, you will return to the Auto Mode Standby screen. If the HAKKO FU-500 receives a Start signal when this screen is displayed, it will start to operate for Auto Mode.

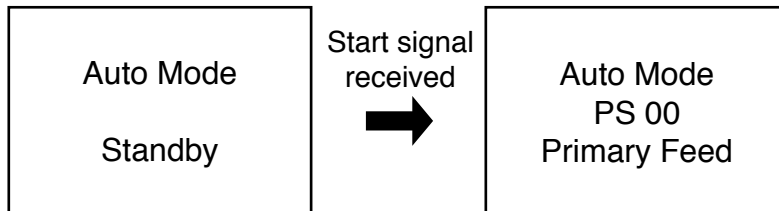

## ●Selecting Simulation Mode

When you select Simulation Mode, you will enter Simulation Mode with the Simulation Mode Standby screen shown. If the HAKKO FU-500 receives a Start signal when this screen is displayed, it will behave in the same manner as in Auto Mode but the motor will not start (no solder will be fed). Note that no solder feed or iron control error will be detected.

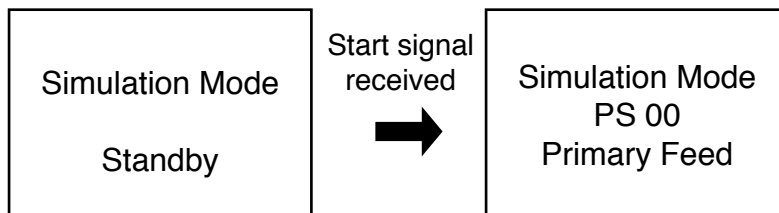

## ●Selecting Test Operation Mode

When you select Test Operation Mode, you will enter Test Operation Mode. In this mode, the HAKKO FU-500 will start to operate in PS (point soldering) mode for operation check or adjustment after selecting a program number. The HAKKO FU-500 outputs the same signal to the robot as the output signal in Auto Mode. All input signals from the robot will be ignored, but any solder feed error will be detected and displayed.

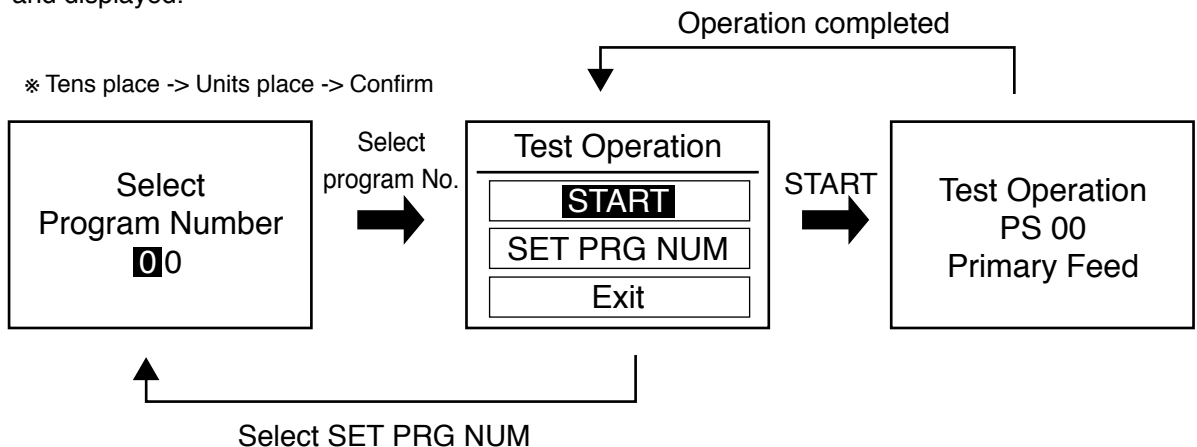

## ●Selecting Solder Feed

When you select Solder Feed, you will enter Solder Feed Mode.  
 In this mode, you will specify the solder feed speed for continuous feed of solder.  
 No signal will be output to the robot. All input signals from the robot will be ignored and  
 no solder feed error will be detected.

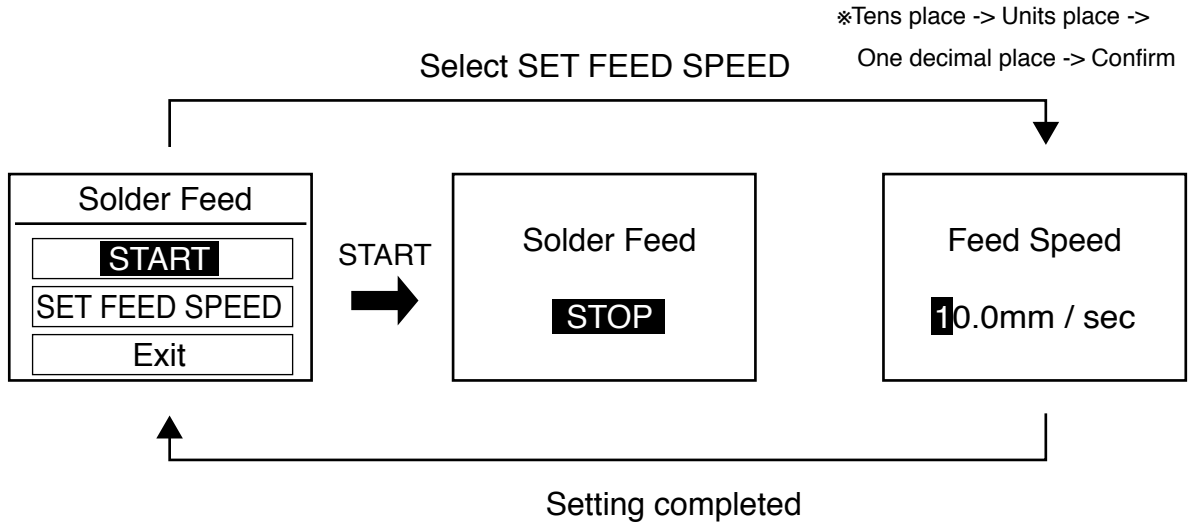

## ●Selecting Program Set

When you select Program Set, you will enter Program Setting Mode.  
 Up to 100 programs (0 to 99) can be programmed in either  
 PS (point soldering) or DS (drag soldering) mode.

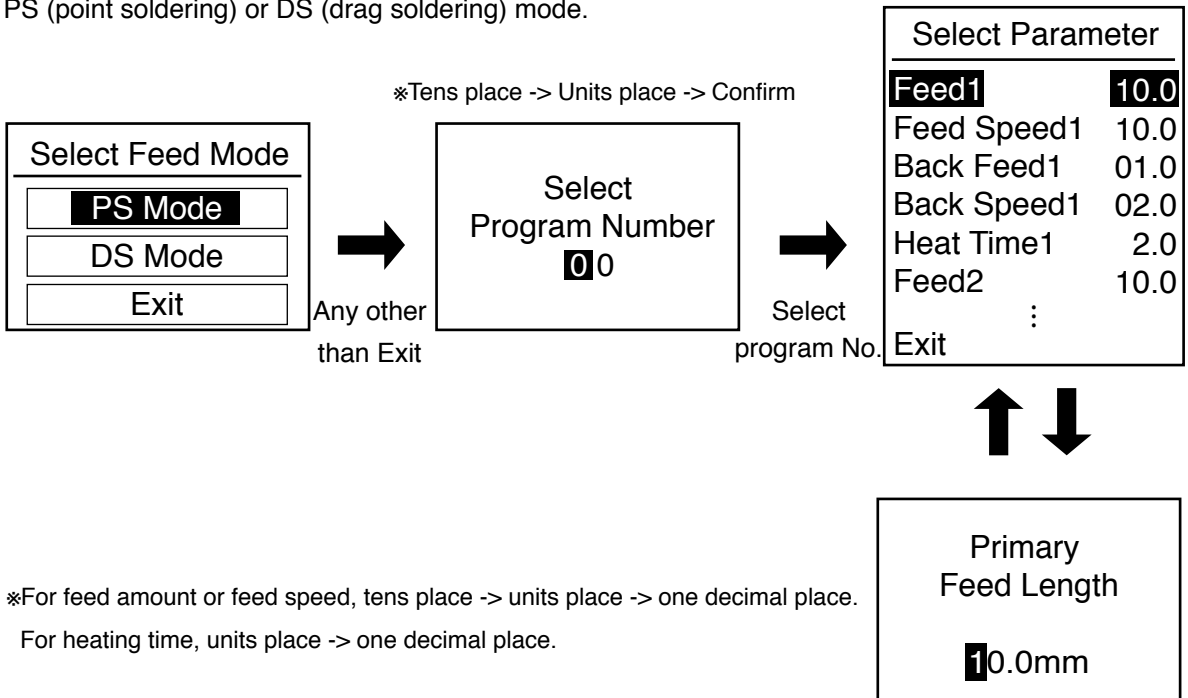

\*For feed amount or feed speed, tens place -> units place -> one decimal place.  
 For heating time, units place -> one decimal place.

---

In Program Setting Mode, the following settings can be made:

Feed 1 :	Primary Feed Length	0.1 - 99.9mm
Feed Speed 1 :	Primary Feed Speed	0.1 - 99.9mm/sec
Back Feed 1 :	Primary Back Feed Length	0 - 20.0mm
Back Speed 1 :	Primary Back Speed	0 - 99.9mm/sec
Heat Time 1 :	Primary Heat Time	0.1 - 9.9sec
Feed 2 :	Secondary Feed Length	0 - 99.9mm
Feed Speed 2 :	Secondary Feed Speed	0 - 99.9mm/sec
Back Feed 2 :	Secondary Back Feed Length	0 - 20.0mm
Back Speed 2 :	Secondary Back Speed	0 - 99.9mm/sec
Heat Time 2 :	Secondary Heat Time	0 - 9.9sec
Feed 3 :	Tertiary Feed Length	0 - 99.9mm
Feed Speed 3 :	Tertiary Feed Speed	0 - 99.9mm/sec
Back Feed 3 :	Tertiary Back Feed Length	0 - 20.0mm
Back Speed 3 :	Tertiary Back Speed	0 - 99.9mm/sec
Heat Time 3 :	Tertiary Heat Time	0 - 9.9sec
Preset # :	Iron Ctrl Preset Number	- (Non) / 0 to 5 *1
Status Sig :	Status Signal Format	Format 1 / Format 2

■ In either secondary or tertiary, setting the feed speed, feed length or heating time to 0 (zero) will skip the corresponding feed or heating operation.

■ Setting any back speed or back feed length to 0 (zero) will skip the corresponding back feed operation.

■ Note that the secondary feed length cannot be set for DS mode.

\*1 The solder might not be properly fed when setting at high speed depending on type of the solder. Contact your HAKKO representative.

\*2 When the Preset Number is set to "Non", the set temperature at start-up of the program will be used for operation.

---

## ● Selecting Parameter Set

When you select Parameter Set, you will enter Parameter Setting mode. In this mode, you can specify the operation of the entire system.

Parameter Set	
<b>Feed Speed</b>	<b>10.0</b>
S-U Mode	Int
S-U Timeout	30
Iron Connect	Con
Iron Status	Rdy
Exit	

1. Feed Speed (Specifying the feed speed in continuous feed mode)

Feed Speed <b>10.0mm / sec</b>
-----------------------------------

0.1 - 99.9mm / sec

2. S-U Mode (Selecting a slide unit connection mode)

Slide Unit Connect Mode <b>Int Mode</b> Ext Mode
---

Internal (Int) or External (Ext)

When Internal Mode is selected, all upper/lower limit detection signals from the robot will be ignored.

3. S-U Timeout (Specifying the slide unit upper/lower limit detection timeout)

Slide Unit Time - out <b>30 sec</b>
---

5 - 99 sec



---

4. Iron Connect (Connection status to the HAKKO FU-601)

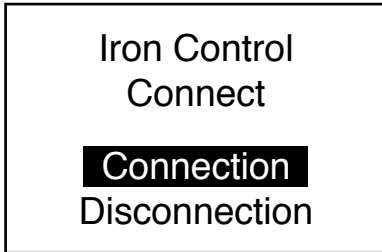

Connection or Disconnection

When Not Connect is selected, preset settings can only be made in the HAKKO FU-601 and no iron controller error is detected.

5. Iron Status (Selecting the HAKKO FU-601 Ready or Error signal)

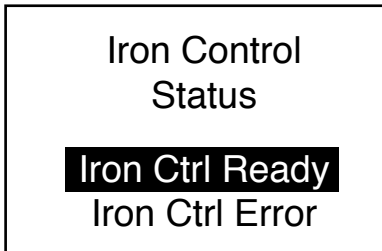

You can select which signal HAKKO FU-601 will output to the robot, Ready or Error.

● **Selecting Log View**

When you select Log View, you can view the number of soldering points that have been made and the total amount of solder that has been fed.

If you select Log Clear, you will enter the Log Clear screen. Selecting OK in this screen will reset the count and you will enter the Mode Select screen.

If you select Cancel, you will return to the previous screen.

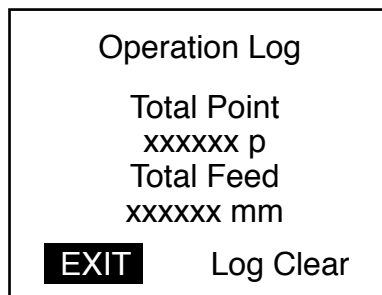

Log Clear



Cancel

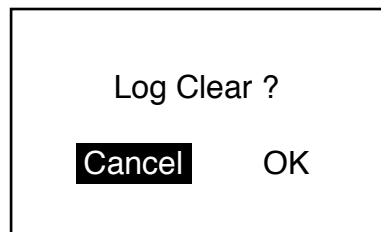

## ● How to change the solder diameter

You can change the solder diameter by replacing the teflon tube, the solder feed guide set or the solder feed pulley unit.

The compatible solder diameters varies by model number of the HAKKO FU-500.

Please check your model number and then see the part list on the back cover of this manual when you need some part replacement.

### ⚠ CAUTION

Only use compatible solder of specified size.  
Failing to do so may cause a failure.  
The attachment of the solder feed pulley unit for  $\varnothing 0.3\text{mm}$  (BX1000) is different.  
Refer to the "How to set solder" in the BX1000.

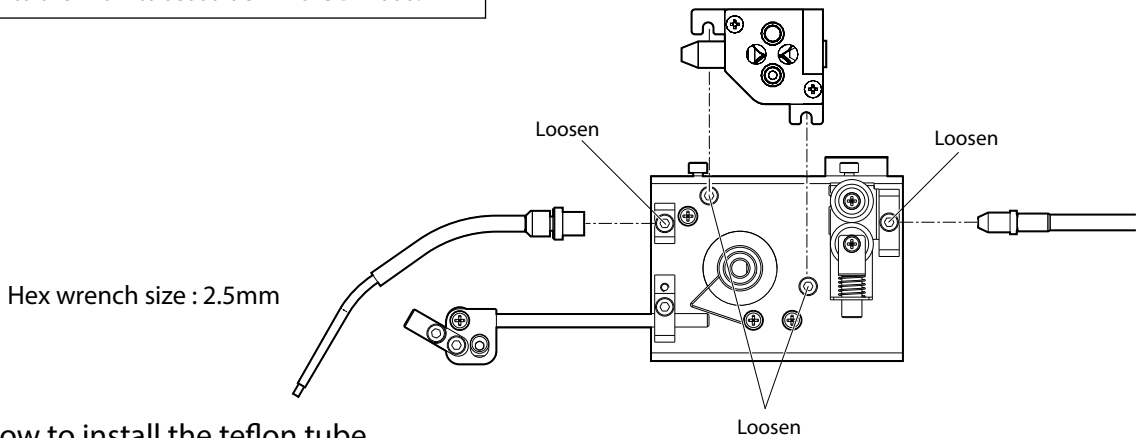

## ● How to install the teflon tube

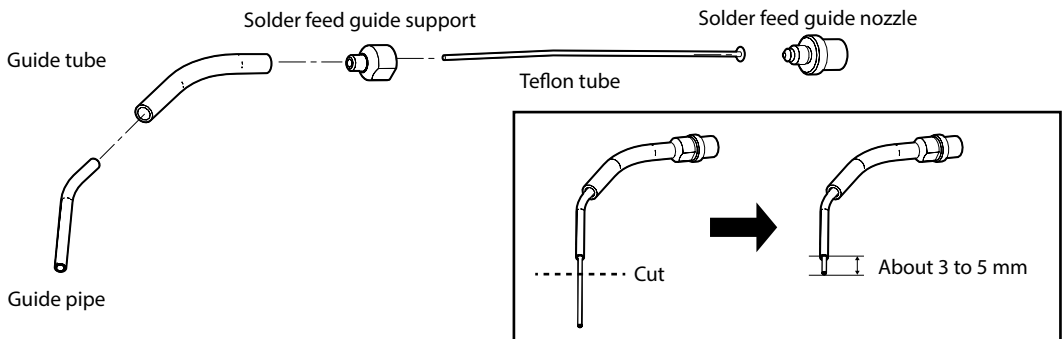

Turn the solder feed guide nozzle counterclockwise and remove the solder feed guide support. You can now install the teflon tube. Lastly, insert the guide pipe.

The teflon tube is quite long in length. Cut the excess length of the teflon tube to leave an appropriate length (about 3 to 5 mm) from the guide pipe before use.

### ⚠ CAUTION

Make sure that the teflon tube protrudes from the guide pipe before use. Otherwise, the guide pipe may be clogged with solder. It is important to use a cutter knife instead of scissors to cut the teflon tube carefully in order to prevent the end of solder wire from being squished.

# 7. MAINTENANCE

■ As a guide, perform maintenance/cleaning when replacing the solder.

Remove any solder or flux adhered on the solder feed pulley unit using a brush or other appropriate tool. If an insufficient cutting depth or splashing of solder balls are found in spite of the proper maintenance, the cutting blade may have reached its end of life.

Since it is impossible to replace the cutting blade only, replace the whole solder feed pulley unit.

After soldering, flux is adhered on the guide pipe part. Regularly wipe off the flux using alcohol.

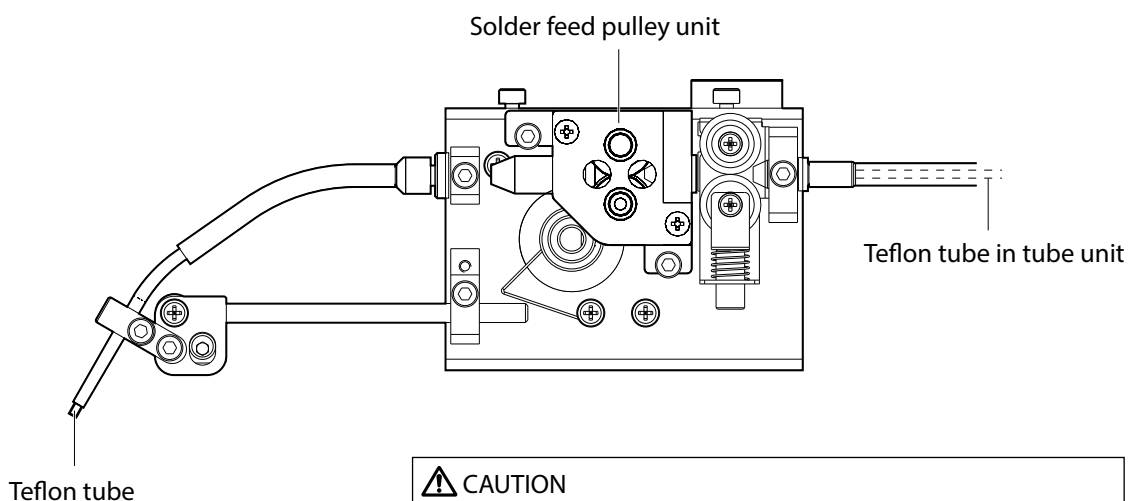

### ⚠ CAUTION

Only the cutting blade and the teflon tube in the tube unit are not interchangeable.

Place which is easy to adhere the solder and flux.

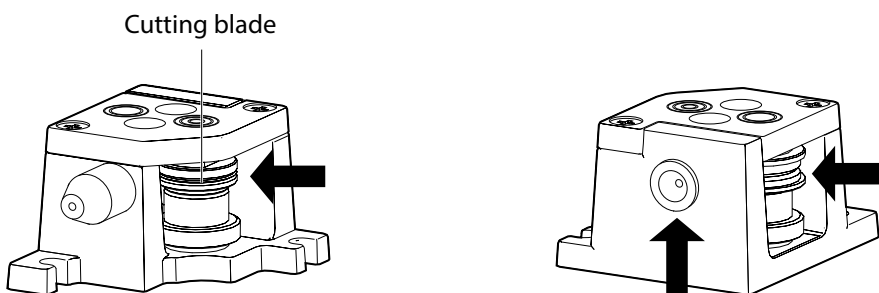

### ⚠ CAUTION

The solder feed pulley unit with the cutting blade is dangerous. Be careful not to cut your fingers.

## 8. ERROR MESSAGES

---

### ● Solder feed trouble error

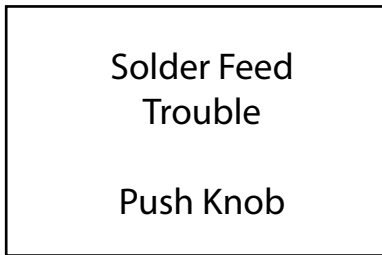

When the solder feed sensor detects "no solder" or "clogging", the HAKKO FU-500 will immediately stop the feed and show this error message on the LCD along with buzzer sound.

### ● Illegal input error

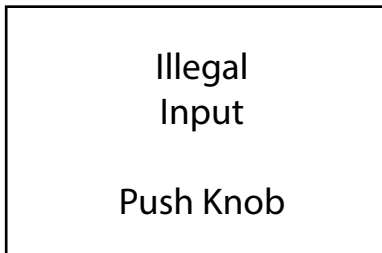

When an illegal input signal from the robot is detected, the HAKKO FU-500 will immediately stop the feed and show this error message on the LCD along with buzzer sound.

### ● Iron Controller Error

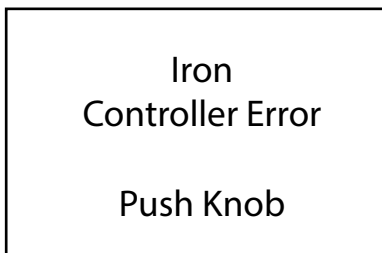

This error message is displayed when the HAKKO FU-601 ready input is "Not Ready" during Auto Mode or Manual Program Mode.

This error will not occur in Adjustment Mode or Continuous Feed Mode.

If the HAKKO FU-601 ready input is "Not Ready" before Auto Mode or Manual Program Mode is started up, the system will not turn into error status but remain standby status.

When this error occurs, the HAKKO FU-500 will immediately stop the feed and show this error message on the LCD along with buzzer sound.

---

## ●Motor Driver Error

Motor Driver  
Error

When abnormal heating of the motor driver is detected, the HAKKO FU-500 will immediately stop the feed and show this error message on the LCD along with buzzer sound.

## ●System Error

System  
Error

When a hardware error is detected, the HAKKO FU-500 will immediately stop the feed and show this error message on the LCD along with buzzer sound.

## ●Emergency Stop

Emergency  
Stop !

Push Knob

Upon receiving an emergency stop command from the robot, the HAKKO FU-500 will immediately stop the feed and show this error message on the LCD along with buzzer sound.

# 9. TROUBLE SHOOTING GUIDE

---

## ●Solder cannot be fed properly. / Solder Feed error is displayed.

**CHECK** : Is "solder clogging" or "no solder" occurred?

**ACTION** : Remove any clogged solder. For "no solder" error, add new solder.

**CHECK** : Is the cutting blade or the pulley deposited with flux?

**ACTION** : Remove any flux using a brush and alcohol.

(See 7. MAINTENANCE in page 18.)

**CHECK** : Is the tube unit or the teflon tube contaminated, worn away and damaged?

**ACTION** : Replace the part.

(See 7. MAINTENANCE in page 18.)

**CHECK** : Is the tube unit forced?

**ACTION** : Relax the tube unit.

(Secure the bending radius of more than 10 cm.)

**CHECK** : Is the teflon tube or the guide pipe clogged with flux?

**ACTION** : Remove any flux using a brush and alcohol.

If the problem persists, replace the part.

**CHECK** : Is the part such as the solder feed pulley unit corresponded to the solder diameter?

**ACTION** : Replace the part with the correct one.

(See 11. PARTS LIST in page 23.)

## ●Illegal Input error is displayed.

**CHECK** : Is the HAKKO FU-500 received any overlapped or illegal signal from the robot?

**ACTION** : Check the robot program.

## ●Iron Controller Error is displayed.

**CHECK** : Does the soldering iron have a sensor failure, too low temperature or any other faulty condition?

**ACTION** : Check the soldering iron.

## ●Motor Driver Error is displayed.

**CHECK** : Does the motor or the motor driver have any faulty condition?

**ACTION** : Contact your HAKKO representative.

## ●System Error is displayed.

**ACTION** : Contact your HAKKO representative.

## ●Emergency Stop is displayed.

**ACTION** : Check the command from the robot.

# 10. EXPLODED VIEW

## ●HAKKO FU-500

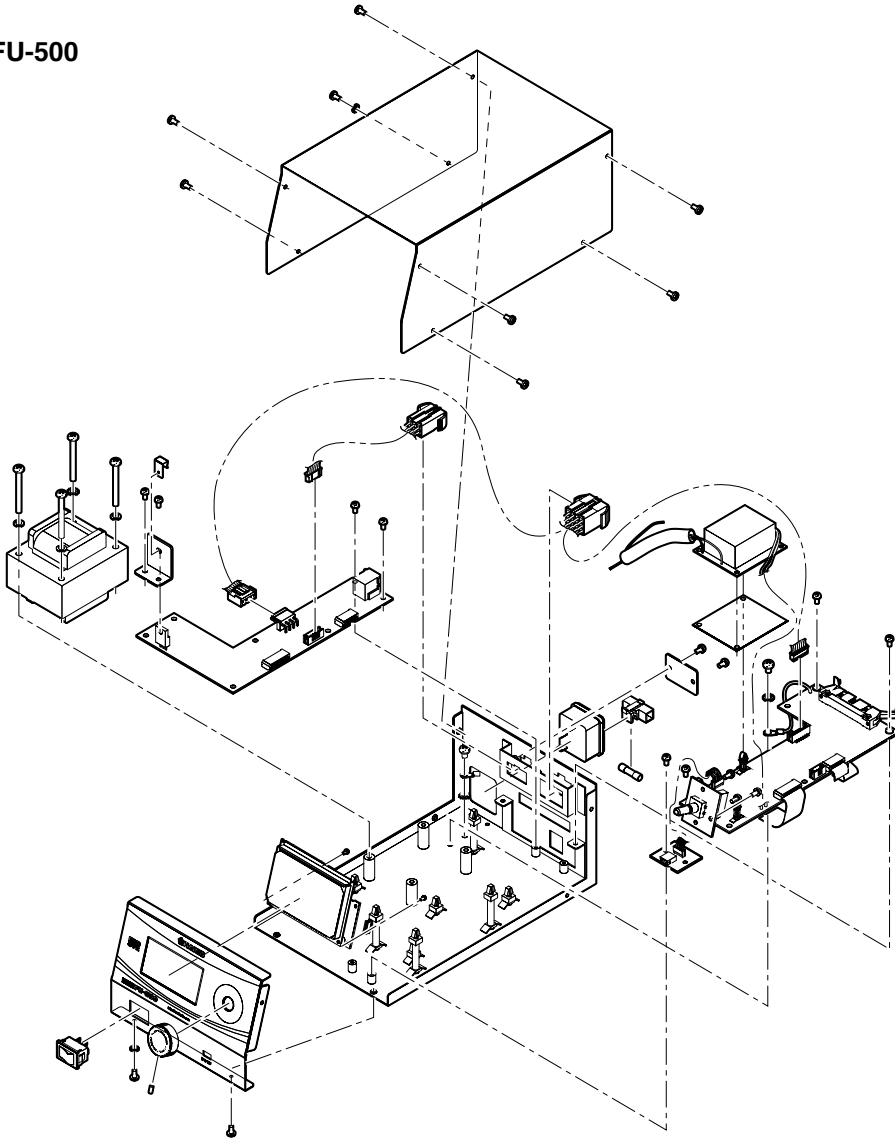

## ●Feeder unit

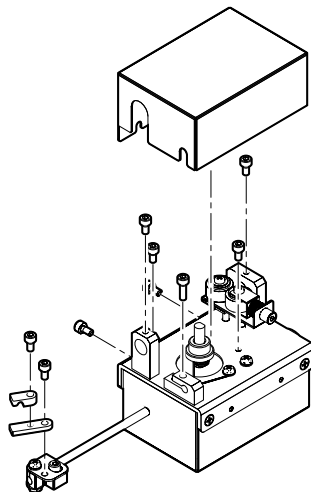

# 11. PARTS LIST

For more information about replacement parts or latest information, please visit our website (<http://www.hakko.com>) or HAKKO Document Portal. (see below)

Part No.	Part Name	Specifications
BX1000	Solder feed pulley unit / 0.3 mm	
BX1001	Solder feed pulley unit / 0.5 mm	
BX1002	Solder feed pulley unit / 0.6 mm	
BX1003	Solder feed pulley unit / 0.8 mm	
BX1004	Solder feed pulley unit / 1.0 mm	
BX1005	Solder feed pulley unit / 1.2 mm	
BX1006	Solder feed pulley unit / 1.6 mm	

Solder feed pulley unit

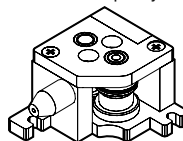

Part No.	Part Name	Specifications
BX1007	Solder feed guide set / 0.3 mm	
BX1008	Solder feed guide set / 0.5 - 1.0 mm	
BX1009	Solder feed guide set / 1.2 - 1.6 mm	

Solder feed guide set

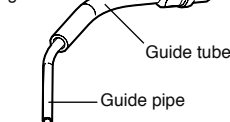

Teflon tube

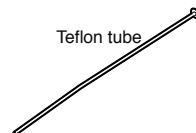

Part No.	Part Name	Specifications
BX1010	Teflon tube / 0.3 mm	set of 10
BX1011	Teflon tube/ 0.5 - 0.6 mm	
BX1012	Teflon tube/ 0.8 mm	
BX1013	Teflon tube / 1.0 mm	
BX1014	Teflon tube / 1.2 mm	
BX1015	Teflon tube / 1.6 mm	

Tube unit

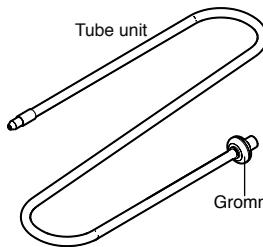

Grommet

Feeder cable

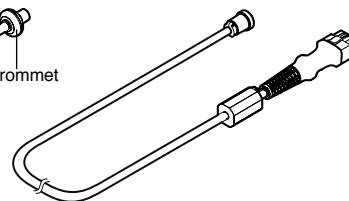

Part No.	Part Name	Specifications
BX1041	Tube unit / 0.3 - 1.0 mm	
BX1042	Tube unit / 1.2 - 1.6 mm	

Part No.	Part Name	Specifications
BX1018	Guide tube	
BX1019	Guide pipe / 0.3 mm	
BX1020	Guide pipe / 0.5 - 1.0 mm	
BX1021	Guide pipe/ 1.2 - 1.6 mm	
BX1022	Grommet	
BX1057	Solder reel stand	
BX1036	Feeder cable / 5 m	With ferrite core
BX1037	Feeder cable / 8 m	core

Solder reel stand

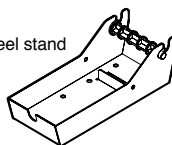

Feeder unit

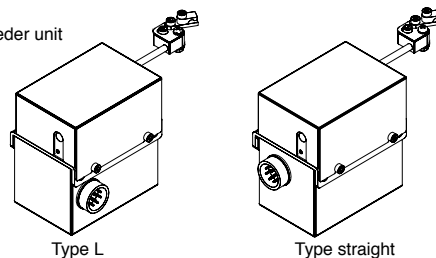

Type L

Type straight

Part No.	Part name	Specifications
CX1010	Feeder unit / 0.3 - 1.6 mm	Type L
CX5006	Feeder unit / 0.3 - 1.6 mm	Type straight



## HAKKO CORPORATION HEAD OFFICE

4-5, Shiokusa 2-chome, Naniwa-ku, Osaka 556-0024 JAPAN  
TEL: +81-6-6561-3225 FAX: +81-6-6561-8466  
<https://www.hakko.com> E-mail: [sales@hakko.com](mailto:sales@hakko.com)

## OVERSEAS AFFILIATES

U.S.A.: AMERICAN HAKKO PRODUCTS, INC.  
TEL: (661) 294-0090 FAX: (661) 294-0096  
Toll Free (800) 88-HAKKO  
<https://www.hakkoUSA.com> E-mail: [Support@HakkoUSA.com](mailto:Support@HakkoUSA.com)

HONG KONG: HAKKO DEVELOPMENT CO., LTD.  
TEL: 2811-5588 FAX: 2590-0217  
<https://www.hakko.com.cn> E-mail: [info@hakko.com.hk](mailto:info@hakko.com.hk)

SINGAPORE: HAKKO PRODUCTS PTE., LTD.  
TEL: 6748-2277 FAX: 6744-0033  
<https://www.hakko.com.sg> E-mail: [sales@hakko.com.sg](mailto:sales@hakko.com.sg)

※ 各言語(日本語、英語、中国語、フランス語、ドイツ語、韓国語)の取扱説明書は以下の URL、HAKKO Document Portal からダウンロードしてご覧いただけます。  
(商品によっては設定の無い言語がありますが、ご了承ください。)  
・ 各言語(日本語、英語、中文、法語、ドイツ語、韓国語)的使用説明書は以下网站的 HAKKO Document Portal 下載參閱。  
(有一部分的产品没有设定外语对应, 請見諒)  
・ Instruction manual in the language of Japanese, English, Chinese, French, German, and Korean can be downloaded from the HAKKO Document Portal.  
(Please note that some languages may not be available depending on the product.)

Please access the web address below for other distributors.

<https://www.hakko.com>



<https://doc.hakko.com>