



# **HAKKO 373** SELF FEEDER

## SELF FEEDER Instruction Manual

Thank you for purchasing the HAKKO 373 Self Feeder. Please read this manual carefully before operating the HAKKO 373. Store the manual in a safe, easily accessible place for future reference.



**CAUTION:** You must install the Solder Dia. Adjustment Ring before use.

### TABLE OF CONTENTS

Precautions .....	1
Specifications .....	1
Names of Parts .....	2
Setting Up the HAKKO 373 .....	3
Operation .....	6
Replacement of Parts .....	8
Options & Replacement Parts .....	9
Parts List .....	11
Troubleshooting Guide .....	13

# Precautions



Setting up should be done while the soldering iron is cool, or you may get burnt.  
Do not force the guide pipe bend or turn as this may result in damage.  
Do not operate with tube bending or holding in sharp angle. It may cause to clogging.  
Input of switching is no-voltage input. Do not apply voltage to the jack for switch.  
Periodically, remove the guide pipe and clean out clogged flux.  
Do not force the adjustment screw to adjust the amount of solder return. It may cause to damage.  
If the power cord is damaged, it must be replaced by the manufacturer, its service agent or similarly qualified person in order to avoid personal injury or damage to the unit.

# Specifications

## Usable Solder

Usable solders are as follows. Some of the parts should be changed according to the diameter of solder desired to use.

Dia. of solder	(mm)	0.6, 0.65, 0.8, 1.0, 1.2, 1.6
	(inch)	0.024, 0.025, 0.031, 0.039, 0.047, 0.063

Maximum quantity of usable solder is 1 kg (2.2 pounds).

## Usable Soldering Iron

Soldering Iron	Remarks
HAKKO 900M (For HAKKO 926, 927, 928)	
HAKKO 900L (For HAKKO 926, 927, 928)	
HAKKO 902 (For HAKKO 931)	
HAKKO 903 (For HAKKO 939)	
HAKKO 904 (For HAKKO 929)	
HAKKO DASH	
HAKKO MACH-I	Operationable only with Foot Switch
HAKKO 907 (For HAKKO 936, 937)	
HAKKO 908 (For HAKKO 936, 937)	

## Specifications

Power Consumption	6 W
Motor Rate	DC 24 V 3.2W
Solder Feed Time	0~7 sec.
Solder Feed Speed	4.5~26 mm (0.14~1 in.)/sec.
Solder Feed Quantity	0~182 mm (0~7.2 in.)
Solder Return Quantity	0~5 mm (0~0.2 in.) (Fixed Speed)
Outer Dimensions	107(W) x 110(H) x 215(D)
Weight	Approx.1.5 kg/3.3 pounds

# Names of Parts

- Jack for Switch
- Feed Speed Control Knob
- Feed Time Control Knob
- Mode Switch
- Power Switch

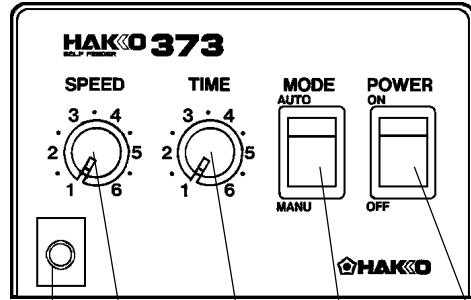

- Release Lever
- Securing Screw
- Tension Adjustment Knob
- Tension Gear Guide Shaft
- Adjustment for the amount of solder return
- Feed Gear
- Supply Nozzle
- Solder Bobbin Shaft

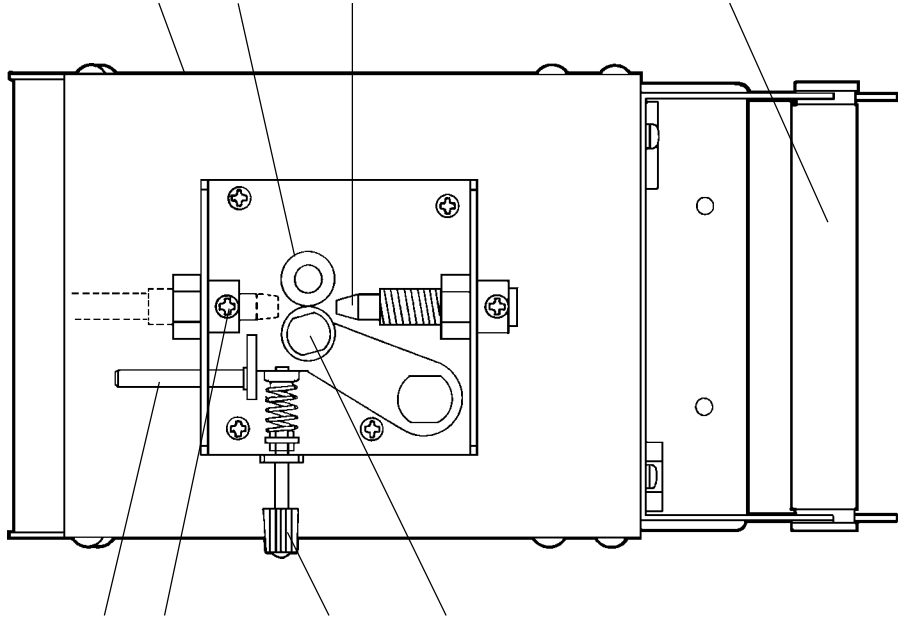

- Solder Dia. Adjustment Ring
- Tension Gear

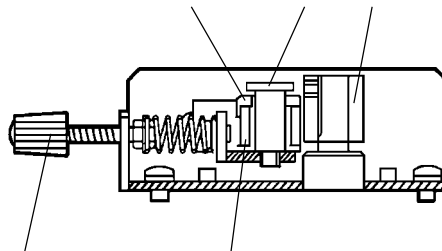

# Setting Up the HAKKO 373

Setting up should be done while the soldering iron is cool, or you may get burnt.

Do not force the guide pipe bend or turn as this may result in damage.

Do not operate with tube bending or holding in sharp angle. It may cause to clogging.

## 1. Install the Solder Dia. Adjustment Ring

1. Remove the tension gear guide shaft.
2. Attach the solder dia. adjustment ring according to the diameter of your desired solder and attach the tension gear guide shaft.

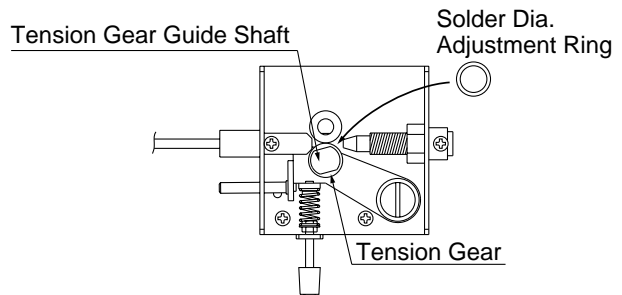

## 2. Setting the Guide Pipe Asse'y

Set the guide pipe asse'y between the nipple (or nut) and handle, and secure it. Washer may need depend on the type of iron. Please refer to the following figure.

HAKKO 900, HAKKO DASH SERIES & 907, 908

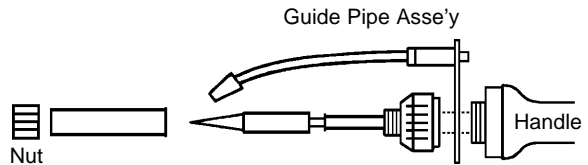

HAKKO 902, 903, 904

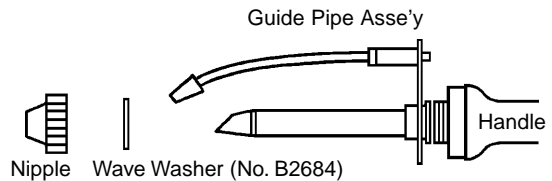

HAKKO MACH-I SERIES

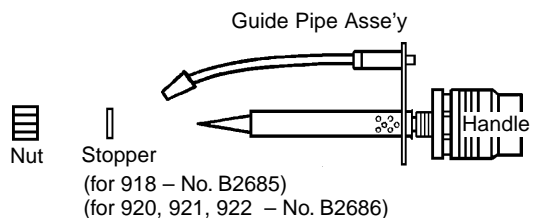

## 3. Setting the Tube Unit

(a) Attach the Tube to Guide Pipe Assembly.

(b) Set the Attachment on the Handle of Soldering Iron.

The tube is double structure. Insert the inside tube into the hole of the connection, and the outside black tube should fully cover the screw part of the connection. Be sure that not to bend the tube.

**NOTE** The Attachment is not necessary if you use HAKKO MACH-I.

- i. Position the attachment on the handle of iron. Decide which outlet of attachment should use for the tube as the tube can be pulled out from either way of the attachment. Find the best position where can connect the tube straight to the pipe. Be careful not to damage the inner wiring if replace the tube inside of the attachment.
- ii. Secure the attachment. Set the attachment on the handle securely with clips and adhesive tape on backside of the attachment. Refer to the following figure on the setting position of the attachment and the guide pipe. Pay attention on the setting angle of the guide pipe and the attachment.

## 4. Connect the Feeding Nozzle

Insert the feeding nozzle into the feeding unit on the top of the station, and secure it with screw.

**NOTE** Securing the screw excessively may break the feeding nozzle.

## 5. Connect the Mini-plug

Insert the mini-plug branching from the tube unit into the jack of the station.

**NOTE** Connect the mini-plug of foot switch to the station if you use HAKKO MACH-I.

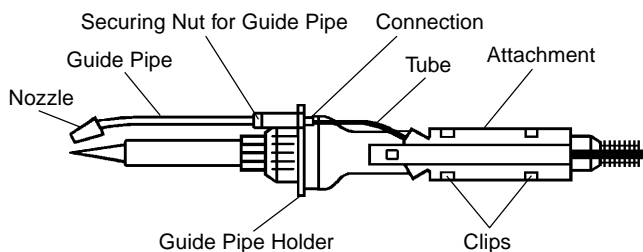

# Setting Up the HAKKO 373

## 6. Setting the Solder

Set a new solder after pull the old solder out when the old one left in tube.

- (a) Remove the tension gear guide shaft. And attach the solder dia. adjustment ring according to the diameter of your desired solder.
- (b) Insert the solder bobbin shaft in the solder bobbin and mount it on rear of the station. Solder should be fed over the bobbin as the following figure.

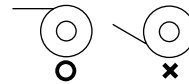

- (c) Insert the solder from the supply nozzle.
- (d) With pressing release lever, put the inserted solder of approx. 10 mm/0.4 in. into the feeding nozzle through between tension gears.
- (e) Power switch on, and set MODE to **MANUAL**.
- (f) Press the trigger switch, and feed the solder.

## 7. Changing the Solder Diameter

Replace the solder dia. adjustment ring, when using the soldering iron continuously but desire to change the diameter of solder. The guide pipe asse'y should change according to the diameter of solder. Refer to the section "Replacement of Parts".

- (a) Power switch off. Open the release lever and roll back the left solder to the bobbin.
- (b) Remove the tension gear guide shaft, and replace the solder dia. adjustment ring according to desired solder dia. Remove the tension gear guide shaft turning with a spanner or pliers.
- (c) Replace the guide pipe asse'y if it's necessary.

## 8. Use in Vertical

Vertical use is available. Fixing in vertical is as following figure.

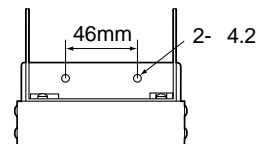

# Operation

Solder will be fed by pressing the feed switch (or foot switch).

## MODE

### Setting for Feeding Time and Speed

### Adjustment for the Amount of Solder Return

### Adjustment of Tension

## AUTO MODE

If you press the feed switch, solder will be fed with set time and speed independently of length of pressing time.

## MANUAL MODE

Solder will be fed with set speed during pressing the feed switch.

Set the speed before the time. For the setting speed, both **AUTO** & **MANUAL** are effective, but only **AUTO** is effective for setting time.

After feed solder, specific length of solder can be returned. This solder return function permits use for simple robots. Amount of solder return is adjustable within 0~13 mm (0~0.51 in.). Solder should be rolled back if the amount of solder return is bigger than the amount of solder feed. Please set the amount of solder return as small as possible. If the tip of the returning solder reaches to the guide pipe, flux will easily accumulate at this point. Be sure that it will not happen. Insert a driver into a adjustment hall on the side of the station. Turn left for smaller and turn right for bigger amount.

When adjust the tension, be sure that not the gear to be slipped during feed solder, or do not force to feed solder slipping gear when solder clog.

Set the tension gear loosely for fine solder ( 0.6mm, 0.8mm/0.024 in., 0.031 in.). Refer to the following chart.

Solder Dia.	ø0.6mm	ø1.0mm	ø1.6mm
$l$	maximum	14mm	10mm

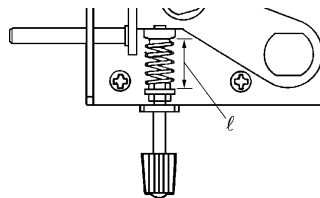

# Operation

## Usage of Iron Holder

- HAKKO 926

If you use HAKKO 926, refer to the following figure to set the iron holder. (As for the HAKKO 926, the setting is available only on it's left.)

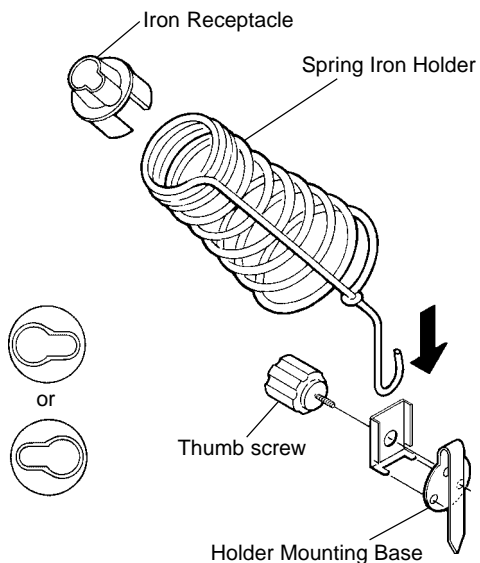

*Set the iron receptacle in the spring iron holder keeping the iron tip and the guide pipe horizontally.*

- HAKKO 631

Simply replace the iron holder if you use with iron holder HAKKO 631 for except HAKKO 926.

- HAKKO 907, 908

Place the soldering iron in the iron holder so that the right side of the guide pipe holder fits to the right side of the iron receptacle.

When you want to fit it to the left side of the iron receptacle, remove the securing nut for the guide pipe and the connection; then reattach them in the opposite side.

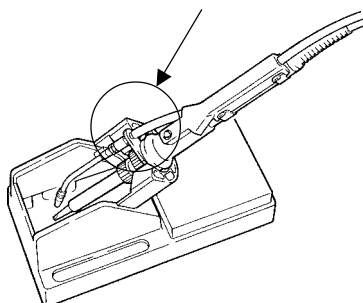



# Replacement of Parts

## 1. When you change the Solder Diameter

Please replace the parts indicated on the following chart when you change solder diameter.

Changing matter	Solder Dia. Adjustment Ring	Nozzle	Guide Pipe	Tube Unit
From the range of 0.6~1.0mm to the range of 0.6~1.0mm	replace	replace	same	same
From the range of 1.2~1.6mm to the range of 1.2~1.6mm	replace	replace	same	same
From the range of 0.6~1.0mm to the range of 1.2~1.6mm	replace	replace	replace	replace
From the range of 1.2~1.6mm to the range of 0.6~1.0mm	replace	replace	replace	replace

## 2. When you change the Soldering Iron

Please replace the tube unit and guide pipe asse'y, when you change the soldering iron. It is not necessary to replace the parts if the items are in the same frame in the following chart. Foot switch is necessary if you use the HAKKO MACH-I.

Tube Unit	900M, 900L, N452, N453, N454	902, 903, 904	918, 920, 921, 922	907, 908
Guide Pipe Asse'y	N452, N453, 900M	N454, 900L	920, 921, 922   918	902, 903, 904   907   908

# Options & Replacement Parts

Part No.	Part Name	Dia. of Solder	Soldering Iron
B1626	Solder Dia. Adjustment Ring	0.6, 0.65mm	-
B1627	Solder Dia. Adjustment Ring	0.8mm	-
B1628	Solder Dia. Adjustment Ring	1.0mm	-
B1629	Solder Dia. Adjustment Ring	1.2mm	-
B1630	Solder Dia. Adjustment Ring	1.6mm	-
B1631	Tube Unit A/with Switch	0.6~1.0mm	900M, 900L, DASH
B1672	Tube Unit B/with Switch	1.2~1.6mm	
B1632	Tube Unit C	0.6~1.0mm	MACH-I
B1673	Tube Unit D	1.2~1.6mm	
B1957	Tube Unit E/with Switch	0.6~1.0mm	902, 903, 904
B1958	Tube Unit F/with Switch	1.2~1.6mm	
B2143	Tube Unit J/with Switch	0.6~1.0mm	907, 908
B2144	Tube Unit K/with Switch	1.2~1.6mm	
B1674	Guide Pipe Asse'y	0.6, 0.65mm	900M, N452, N453
B1675	Guide Pipe Asse'y	0.8mm	
B1676	Guide Pipe Asse'y	1.0mm	
B1677	Guide Pipe Asse'y	1.2mm	
B1678	Guide Pipe Asse'y	1.6mm	
B1679	Guide Pipe Asse'y	0.6, 0.65mm	900L, N454
B1680	Guide Pipe Asse'y	0.8mm	
B1681	Guide Pipe Asse'y	1.0mm	
B1682	Guide Pipe Asse'y	1.2mm	
B1683	Guide Pipe Asse'y	1.6mm	
B1684	Guide Pipe Asse'y	0.6, 0.65mm	920, 921, 922
B1685	Guide Pipe Asse'y	0.8mm	
B1686	Guide Pipe Asse'y	1.0mm	
B1687	Guide Pipe Asse'y	1.2mm	
B1688	Guide Pipe Asse'y	1.6mm	
B1689	Guide Pipe Asse'y	0.6, 0.65mm	918
B1690	Guide Pipe Asse'y	0.8mm	
B1691	Guide Pipe Asse'y	1.0mm	
B1692	Guide Pipe Asse'y	1.2mm	
B1693	Guide Pipe Asse'y	1.6mm	

## Options & Replacement Parts

Part No.	Part Name	Dia. of Solder	Soldering Iron
B1694	Guide Pipe Asse'y	0.6, 0.65mm	902, 903, 904
B1695	Guide Pipe Asse'y	0.8mm	
B1696	Guide Pipe Asse'y	1.0mm	
B1697	Guide Pipe Asse'y	1.2mm	
B1698	Guide Pipe Asse'y	1.6mm	
B2146	Guide Pipe Asse'y	0.6, 0.65mm	907
B2147	Guide Pipe Asse'y	0.8mm	
B2148	Guide Pipe Asse'y	1.0mm	
B2149	Guide Pipe Asse'y	1.2mm	
B2150	Guide Pipe Asse'y	1.6mm	
B2151	Guide Pipe Asse'y	0.6, 0.65mm	908
B2152	Guide Pipe Asse'y	0.8mm	
B2153	Guide Pipe Asse'y	1.0mm	
B2154	Guide Pipe Asse'y	1.2mm	
B2155	Guide Pipe Asse'y	1.6mm	
B1699	Nozzle	0.6, 0.65mm	-
B1700	Nozzle	0.8mm	-
B1701	Nozzle	1.0mm	-
B1702	Nozzle	1.2mm	-
B1703	Nozzle	1.6mm	-
B1704	Guide Pipe A	0.6~1.0mm	900M, 920, 921, 922
B1705	Guide Pipe B	1.2~1.6mm	
B1706	Guide Pipe C	0.6~1.0mm	900L, 918, N454, 908
B1707	Guide Pipe D	1.2~1.6mm	
B1708	Guide Pipe E	0.6~1.0mm	902, 903, 904
B1709	Guide Pipe F	1.2~1.6mm	
B1647	Spring Iron Holder A	-	926
B1648	Spring Iron Holder B	-	927, 928, 929, 931
B1649	Foot Switch	-	-
B1650	Clip A/1 pc	-	900M, 900L, DASH
B1956	Clip B/1 pc	-	902, 903, 904
B2158	Clip C/1 pc	-	907, 908
631-07	HAKKO631 Iron Holder	-	DASH, MACH-I
B1863	Mini-plug	-	-
B1805	Iron Receptacle	-	-
C1234	Feeder Pen A	0.6~1.0mm	-
C1235	Feeder Pen B	1.2~1.6mm	-
B2124	Feeder Switch	-	-

■ 900M, 900L are Iron Parts for HAKKO 926, 927, 928.

■ 902 is Iron Part for HAKKO 931.

■ 903 is Iron Part for HAKKO 929, 939 (120V).

■ 904 is Iron Part for HAKKO 929 (100, 110, 220, 230, 240V).

■ 918, 920, 921, 922 are Parts No. of HAKKO MACH-I series. MACH-I means applicable for all items of HAKKO MACH-I series.

■ N452, N453, N454 are Parts No. of HAKKO DASH series. DASH means applicable for all items of HAKKO DASH series.

■ 907, 908 are Iron Parts for HAKKO 936, 937.

Item No.	Part No.	Part Name	Description
1	B1897	Cover for Feeding Unit	
2	B1882	Tension Gear Guide Shaft	
3	B1626	Solder Dia. Adjustment Ring	for 0.6, 0.65mm
	B1627	Solder Dia. Adjustment Ring	for 0.8mm
	B1628	Solder Dia. Adjustment Ring	for 1.0mm
	B1629	Solder Dia. Adjustment Ring	for 1.2mm
	B1630	Solder Dia. Adjustment Ring	for 1.6mm
4	B1885	Tension Gear	
5	B1886	Tension Lever Fixing Shaft	
6	B1908	Washer	for Wave Washer
7	B1894	Tension Lever	w/Screw
8	B1883	Tension Spring	
9	B1881	Feed Gear	w/Screw
10	B1887	Washer	for Tension Lever Fixing Guide
11	B1888	Tension Lever Fixing Guide	
12	B1889	Tension Lever Fixing Washer	
13	B1890	Nozzle Support	w/Nut, Screw
14	B1892	Supply Nozzle	
15	B1891	Motor Fixing Plate	
16	B1893	Release Lever	w/Washer
17	B1884	Tension Adjustment Knob	w/Nuts
18	B1880	Motor	
19	B1898	Cover	
20	B1900	Transformer	100V-24V
	B1909	Transformer	110V-24V
	B1910	Transformer	120V-24V
	B1911	Transformer	220, 230V-24V
	B1912	Transformer	240V-24V
21	B1901	Solder Bobbin Shaft	
22	B1902	Solder Bobbin Support	
23	B1899	P.W.B.	w/Potentiometers
24	B1041	Fuse Holder	w/o Fuse
	B1134	Fuse Holder (S)	w/o Fuse
25	B1907	Fuse	125V-1A/100,110,120V
	B1138	Fuse	250V-1A/220,230,240V
	B1139	Fuse	250V-1A (S) /220,230V
26	B1895	Chassis Support Plate	w/Rubber Stoppers
27	B1904	Knob	
28	B1903	Mini Jack	
29	B1906	Switch	
30	B1487	Power Switch	100-120V
	B2604	Power Switch	220-240V
31	B1197	Potentiometer for Feed Speed Control	5KΩ, w/Nut
32	B1905	Potentiometer for Feed Time Control	1MΩ, w/Nut
33	B1896	Chassis	w/Rubber Stoppers
34	B1037	Rubber Stopper	Set of 4
35	B1114	Locking Spacer	Set of 4
36	B1208	Cord Stopper	
37	B1163	Power Cord	3 Core & American Plug, 100V
	B1007	Power Cord	3 Core But No Plug
	B1168	Power Cord	3 Core & American Plug
	B1169	Power Cord	3 Core & European Plug
	B1214	Power Cord	3 Core & Australian Plug
	B1964	Power Cord	3 Core & BS Plug
38	B2087	Power Cord	3 Wire & BS Plug (CE)
	B2684	Wave Washer	

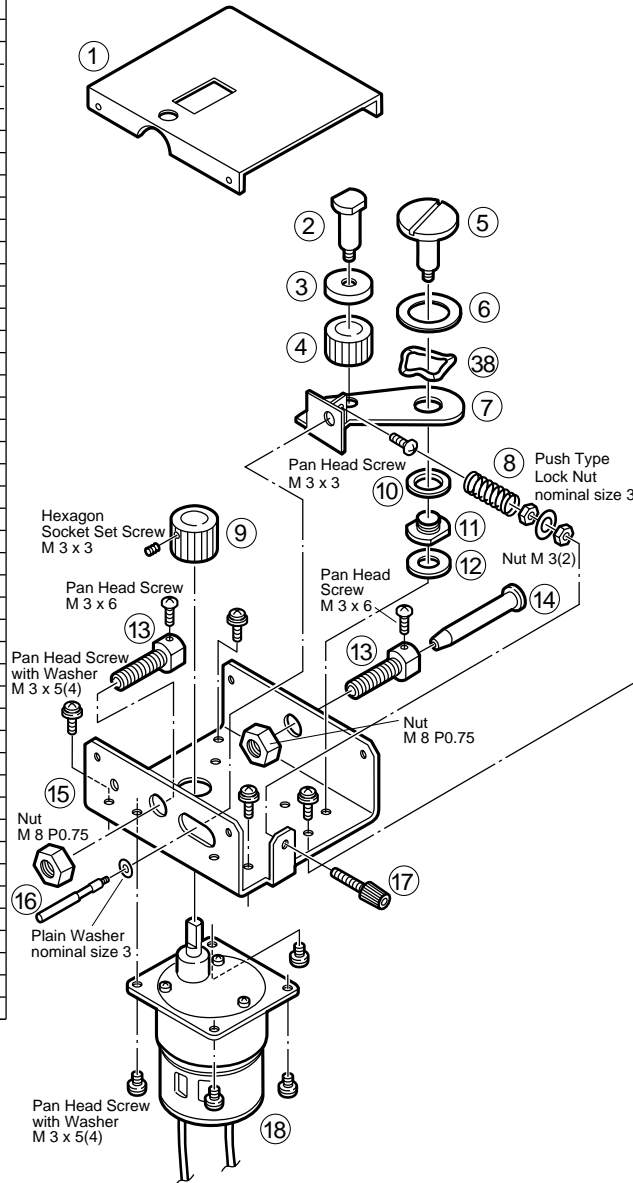

Note: Spare or repair parts do not include mounting screws, if they are not listed on the description.  
Screws must be ordered separately.

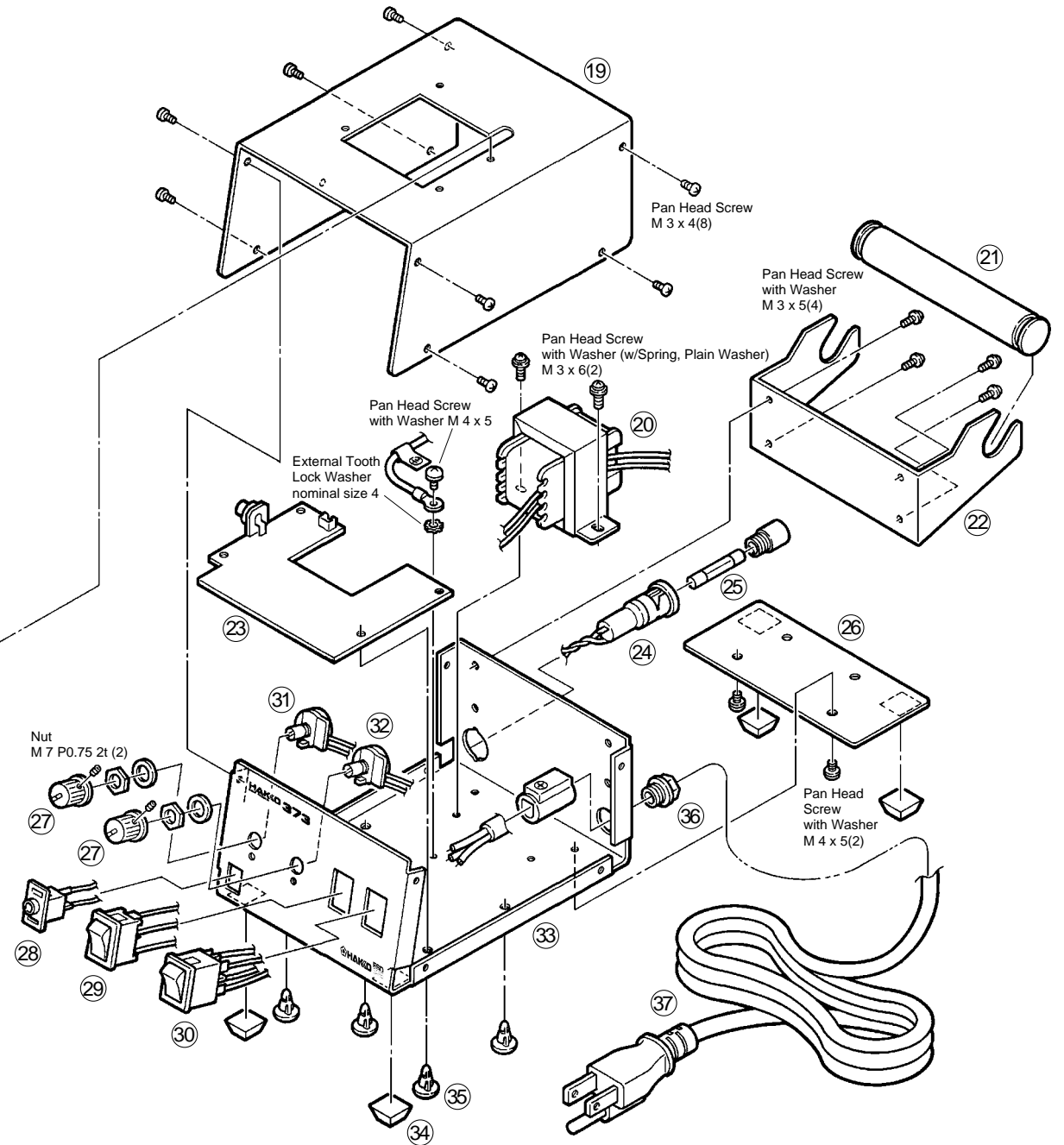

# ***Troubleshooting Guide***

---

If the solder can not be fed smoothly, please check following points.

Are you using proper parts according to the diameter of solder?

Did you adjust the tension properly?

Isn't the tube bent or transformed?

Isn't solder adhered at the feed gear or the tension gear?

Isn't the nozzle clogged with flux?

Is the mini-plug correctly connected?

Isn't the fuse blown?

Is the power cord correctly connected?



**HAKKO CORPORATION**

**HEAD OFFICE**

TEL:+81-6-6561-3225 FAX:+81-6-6561-8466

<http://www.hakko.com> E-mail:sales@hakko.com

**OVERSEAS AFFILIATES**

**U.S.A.: AMERICAN HAKKO PRODUCTS, INC.**

TEL: (661) 294-0090 FAX: (661) 294-0096

Toll Free (800)88-HAKKO

<http://www.hakkousa.com>

**HONG KONG: HAKKO DEVELOPMENT CO., LTD.**

TEL: 2811-5588 FAX: 2590-0217

<http://www.hakko.com.hk>

E-mail:info@hakko.com.hk

**SINGAPORE: HAKKO PRODUCTS PTE., LTD.**

TEL: 6748-2277 FAX: 6744-0033

<http://www.hakko.com.sg>

E-mail:sales@hakko.com.sg

Please access to the following address for the other Sales affiliates.

**<http://www.hakko.com/address>**