

Thank you for purchasing the HAKKO FA-430 Fume Extraction system. Please read this manual before operating the HAKKO FA-430. Keep this manual readily accessible for reference.

1. PACKING LIST AND PART NAMES

Please check to make sure that all items listed below are included in the package.

HAKKO FA-430 Fume extraction system.....	1	Main filter (inside main unit).....	1
Power cord.....	1	Pre-filter.....	10pcs.
Cap (inside main unit).....	1	Instruction manual.....	1

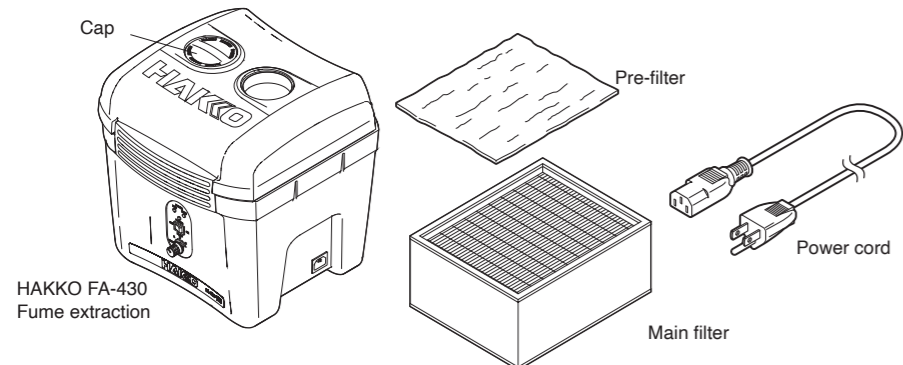

●Duct set (not included)

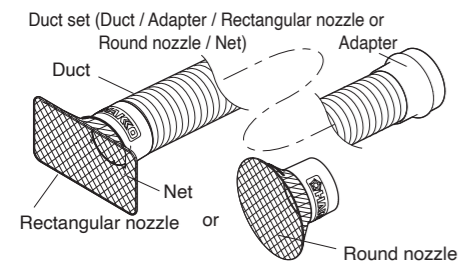

●Option

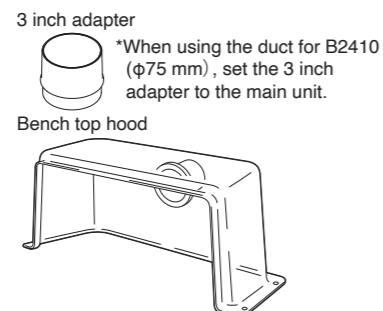

2. SPECIFICATIONS

●HAKKO FA-430

Power Consumption	110W		
Suction Capacity *1	High	Medium	Low
	4.7m³/min	3.7m³/min	2.8m³/min
Filtering Efficiency *2	High: 99.96% / Medium-Low: 99.97%		
Duct diameter	φ55 mm		
Dimensions	330(W) x 366(H) x 343(D) mm		
Weight (w/o cord)	7.5 kg		

*1 When using 2 ducts
*2 It is an initial value of collection efficiency based on counting method for airborne dust collected by a single plate of filter (unfolded).

*Specifications and design are subject to change without notice.

CAUTION

■ Handling precautions for ESD Safe products

This product contains electrostatic countermeasures, so please use the following precautions:
1. Not all plastic parts are insulators, they may be conductive. Be careful not to expose live electrical parts or damage insulating materials when performing repairs or replacing parts.
2. Be sure the product is grounded before use.

HAKKO CORPORATION

HEAD OFFICE
4-5, Shiokusa 2-chome, Naniwa-ku, Osaka 556-0024 JAPAN
TEL: +81-6-6561-3225 FAX: +81-6-6561-8466
https://www.hakko.com E-mail: sales@hakko.com

OVERSEAS AFFILIATES
U.S.A.: AMERICAN HAKKO PRODUCTS, INC.
TEL: (661) 294-0090 FAX: (661) 294-0096
Toll Free (800) 88-HAKKO
https://www.HakkoUSA.com E-mail: Support@HakkoUSA.com

HONG KONG: HAKKO DEVELOPMENT CO., LTD.
TEL: 2811-5588 FAX: 2590-0217
https://www.hakko.com.cn E-mail: info@hakko.com.hk

SINGAPORE: HAKKO PRODUCTS PTE., LTD.
TEL: 6748-2277 FAX: 6744-0033
https://www.hakko.com.sg E-mail: sales@hakko.com.sg

Please access the code for overseas distributors.
https://www.hakko.com/doc_network



3. WARNINGS, CAUTIONS, NOTES AND EXAMPLES

Warnings, cautions and notes are placed at critical points in this manual to direct the operator's attention to significant items. They are defined as follows:

⚠ **WARNING:** Failure to comply with a WARNING may result in serious injury or death.

⚠ **CAUTION:** Failure to comply with a CAUTION may result in injury to the operator, or damage to the items involved.

NOTE: A NOTE indicates a procedure or point that is important to the process being described.

⚠ WARNING

- Do not absorb combustible, explosive or corrosive gas.
- Store the fume extraction unit in a dry place.
- Do not block the exhaust vent of the fume extraction unit.
- Use only genuine HAKKO replacement parts.
- Turn the power off when not in use, or left unattended.
- Turn the power off when changing parts or storing the HAKKO FA-430.
- This appliance is not intended for use by persons (including children) with reduced physical, sensory or mental capabilities, or lack of experience and knowledge, unless they have been given supervision or instruction concerning use of the appliance by a person responsible for their safety.
- Children should be supervised to ensure that they do not play with the appliance.

●To prevent accidents or damage to the HAKKO FA-430, be sure to observe the followings:

⚠ CAUTION

- Do not operate the fume extraction without the filter; otherwise it may cause the unit to malfunction.
- Hold the plug when inserting or removing the cord in/from the outlet.
- Do not allow the HAKKO FA-430 to become wet, or use it with wet hands.
- While using the HAKKO FA-430, don't do anything which may cause bodily harm or physical damage.

4. OPERATION

● Set the filter

1. Open the upper cover and then remove the plastic bag from the main filter.
2. Put the main filter on the main unit. Set the filter with the arrow pointing down (as shown in the illustration).
3. Fit the pre-filter on top of the main filter. (orange side facing up)

⚠ **CAUTION**
Be sure the pre-filter lies flat and completely covers the top of the main filter with no gaps.

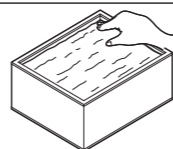

4. Close the upper cover

● Attach the duct

A. How to attach duct set

1. Refer to Figure 1 (right), and attach the nozzle and adapter to the duct. Insert the nozzle and adapter until it stops, turn the nozzle clockwise. Make sure the nozzle and adapter are firmly attached.

⚠ **CAUTION**
Twist the nozzle tight enough to avoid coming off.

2. Fit the net on the nozzle. (Figure 2)

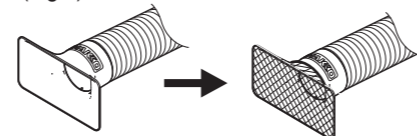

3. Insert the duct into the open port. If using one duct, ensure the cap is in place on the unused port. When using two ducts, please store the cap inside the main unit next to the main filter as shown in Figure 3 (right).

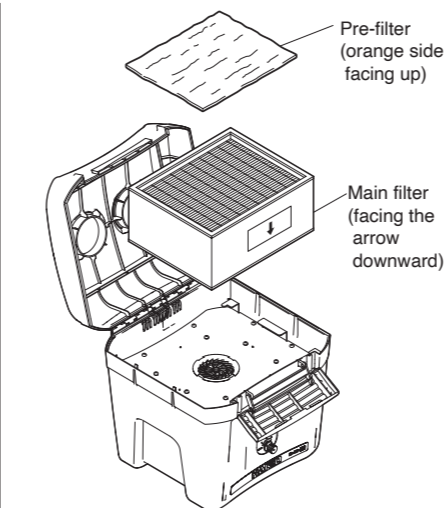

(Fig.1)

Be sure the duct is facing in the proper direction during assembly.

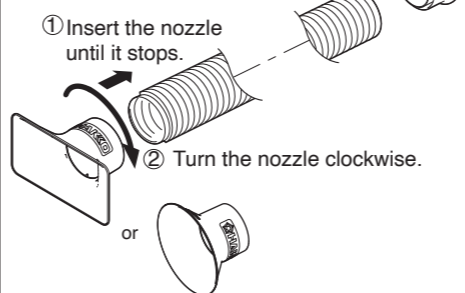

(Fig.2)

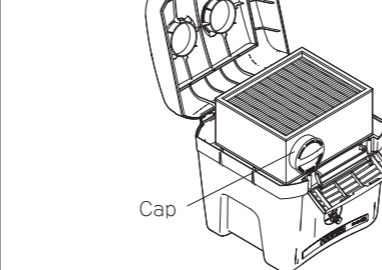

(Fig.3)

4. OPERATION

B. How to attach bench top hood.

When using a bench top hood, the following parts are required:

- 3 inch adapter
- 3 inch duct (φ75)
- Duct band

*Refer to "7. PARTS LIST" for part numbers.
*The standard duct for the HAKKO FA-430 can not be used to connect a bench top hood.

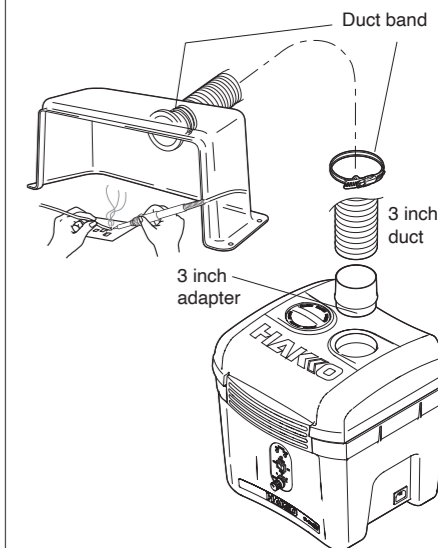

● Fume extraction unit

1. Connect the power cord to the power receptacle on the right of the unit.
2. Plug the power cord into a ground wall socket.
3. Turn the power switch on. Power lamp will light up.

⚠ **CAUTION**
Close the cover before turning the power switch on.

4. Adjust the flow suitable for working environment by using flow selection switch.
5. Adjust the angle of the duct and nozzle as needed for optimal performance.

⚠ CAUTION

- Do not block the open port on purpose.
- When the fan is running, do not open the upper cover.
- Turn the power off when not in use. Failure to do so may result in shorter filter life.
- If it passes more than 2500 hours or one year since the HAKKO FA-430 is used, replace the main filter with new one at once. If using the main filter over replacement timing, doing so may result in damage to the main unit.

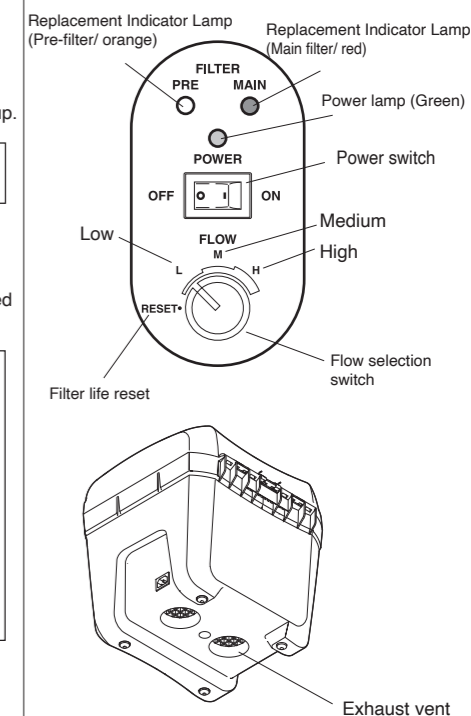

- 各言語（日本語、英語、中国語、フランス語、ドイツ語、韓国語）の取扱説明書は以下の URL、HAKKO Document Portal からダウンロードしてご覧いただけます。（商品によっては設定の無い言語がありますが、ご了承ください。）
- 各言語（日本語、英語、中文、法語、ドイツ語、韓国語）的使用説明書可以通过以下网站的 HAKKO Document Portal 下载参阅。（有一部分的产品没有设定外语对应、请见谅）
- Instruction manual in the language of Japanese, English, Chinese, French, German, and Korean can be downloaded from the HAKKO Document Portal. (Please note that some languages may not be available depending on the product.)

➡ <https://www.hakko.com/english/support/doc/>

5. MAINTENANCE

Performing proper and periodic maintenance extends the product life. Wear of the product will differ depending on work environment, the quality and quantity of the solder and flux. Apply the following service procedure as dictated by the conditions of the usage.

HAKKO FA-430 counts used number of the pre-filter in order to determine the remaining life of the main filter. There are a few points to observe when replacing filters. Read "How to replace the filter" and follow the procedure. Replacing the filter without following the procedure may cause the overuse of the main filter and subsequent damage to the unit.

●Filter replacement timing

Pre-filter : 80% of the pre-filter is clogged or it was used for 200 hours. (The orange lamp flashes.)

Main filter : When the 10th pre-filter needs replacing. (The orange and red lamp flash.)

⚠ CAUTION

Replacing the filter without following the procedure will disrupt the timing for filter replacement and may cause the overuse of the filters and subsequent damage to the unit.

●How to replace the filter

NOTE:

- The lamp status indicates appropriate time to replace the main filter and pre-filter. If continuing to use the main filter or pre-filter after the lamp status indicates it is time for replacement, it may result in reduced performance and/or subsequent damage to the unit.
- When replacing the filter, set the flow selection switch to RESET without turning off the power switch.

A. Pre-filter

NOTE:

Do not lift the main filter when replacing the pre-filter. If the main filter is lifted for more than 3 seconds with the power switch on and the flow control set to RESET, the used number of the pre-filter are reset to zero.

- ① Pre-filter lamp (orange) flashes.
- ② Set the flow selection switch to RESET with the power switch on. (The fan will stop.)
- ③ Open the upper cover and remove the pre-filter only. Fit the new pre-filter on top of the main filter so that it lies flat with no gaps, then close the upper cover.
- ④ Set the flow selection switch back to the previous position. The fan will start running and the unit will return to a normal operating condition.

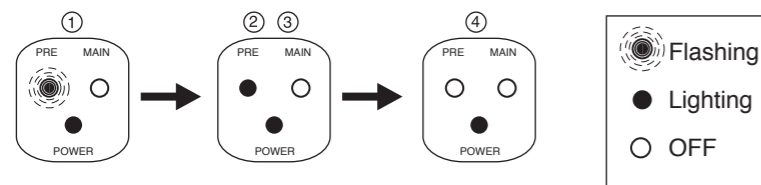

B. Main filter

- ① Pre-filter lamp (orange) and main filter lamp (red) flash.
- ② Set the flow selection switch to RESET with the power switch on. (The fan will stop.)
- ③ Open the upper cover and then remove both main filter and pre-filter. Replace the filters with the new filters, fit them in the main unit and close the upper cover.
- ④ Set the flow selection switch back to the previous position. The fan will start running and the unit will return to a normal operating condition.

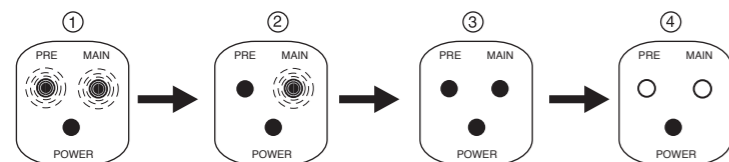

●In case of replacing the pre-filter only with the red and orange lamp flashing.

- ① Pre-filter lamp (orange) and main filter lamp (red) flash.
- ② Set the flow selection switch to RESET with the power switch on. (The fan will stop.)
- ③ Open the upper cover and then remove the pre-filter only. Fit the new pre-filter on top of the main filter so that it lies flat with no gaps, then close the upper cover.
- ④ Set the flow selection switch back to the previous position. After 5 seconds are passed, the red lamp will be turned off.

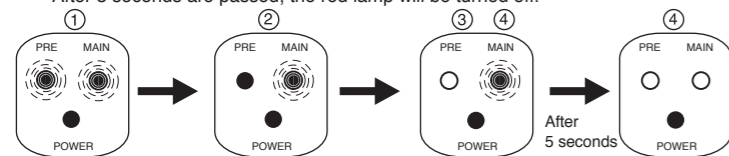

*If not replacing the main filter after the lamp indicated to replace it, the red lamp will flash for 5 seconds every time the power switch is turned on.

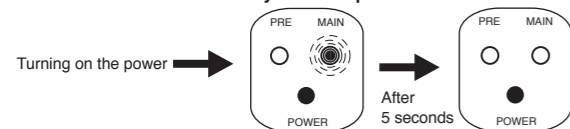

6. TROUBLE SHOOTING GUIDE

- Nothing happens when the power switch is turned on.

CHECK : Is the power cord disconnected ?

ACTION : Connect it.

CHECK : Is the main filter set properly ?

ACTION : Fit the main filter properly before turning on the power switch again.

CHECK : Is the flow control set to RESET ?

ACTION : Adjust the flow suitable for working environment by using the flow selection switch.

CHECK : When replacing the filter, Is the flow selection switch adjusted to RESET with the power switch on ?

ACTION : Make sure that power switch is ON, and set the flow selection switch to RESET again.

CHECK : When replacing the filter, Is the flow selection switch adjusted to RESET with the power switch on ?

ACTION : Make sure that power switch is on and set the flow selection switch to RESET. Lift the main filter more than 3 seconds.

ACTION : Main filter needs to be replaced. Recommend replacing the main filter otherwise performance will be reduced.

ACTION : Main filter has exceeded its service life and was never replaced. It has passed more than 2500 hours since it is used. Main filter must be replaced. Failure to do so may result in damage to the unit.

ACTION : Contact your HAKKO representative because it is necessary to repair the main unit.

- Orange lamp keeps flashing after replacing the pre-filter.

- Red lamp keeps flashing after replacing the main filter.

- Red lamp is flashing for 5 seconds just after turning the power switch on.

- Red lamp lights up.

- All lamp flashes at the same time.

7. PARTS LIST

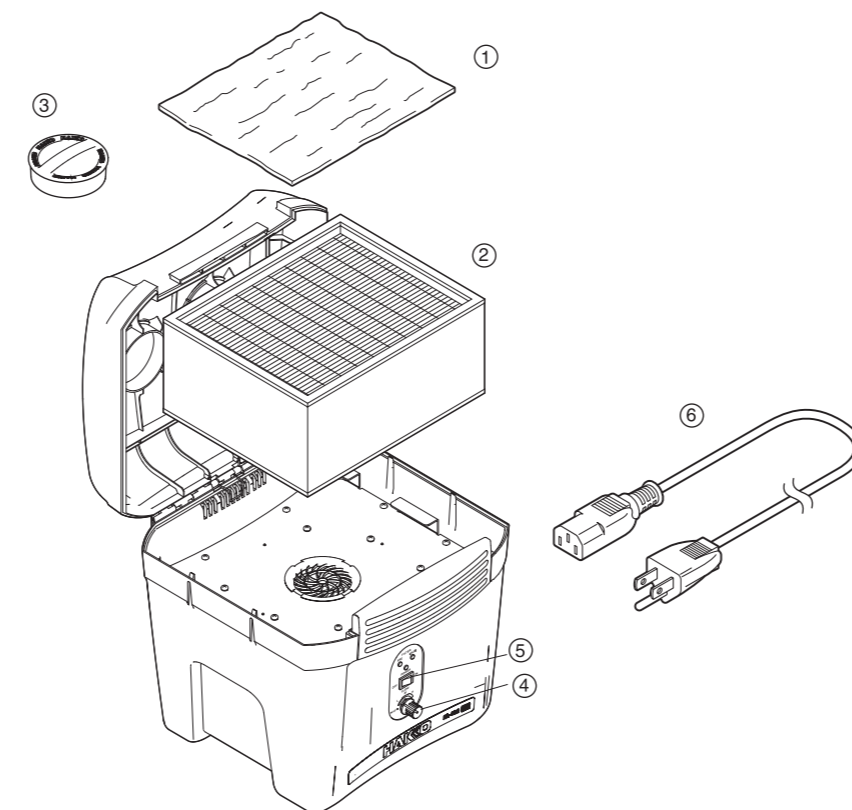

7. PARTS LIST

●HAKKO FA-430

Item No.	Part No.	Part Name	Specifications
①	A1572	Pre-filter	10 pcs.
②	A1573	Main filter	
③	B3619	Cap	
④	B1486	Knob	
⑤	B2852	Power switch	
⑥	B2421	Power cord, 3 wired cord but no plug	220 - 240V
	B2422	Power cord, 3 wired cord & BS plug	India
	B2424	Power cord, 3 wired cord& European plug	220V KTL , 230V CE
	B2425	Power cord, 3 wired cord & BS plug	230V CE , U.K.
	B2426	Power cord, 3 wired cord & Australian plug	
	B2436	Power cord, 3 wired cord & Chinese plug	China
B3508	Power cord, 3 wired cord & American plug		
B3550	Power cord, 3 wired cord & SI plug		
B3616	Power cord, 3 wired cord & BR plug		

●Option

Item No.	Part No.	Part Name	Specifications
①	C1571	Duct set / Rectangular nozzle	Duct (1) / Adapter (1) Rectangular nozzle(1) / Net (1)
		Duct set / Round nozzle	Duct (1) / Adapter (1) Round nozzle (1) / Net (1)
③	B3642	Duct	φ 55 mm
④	B3620	Adapter	
⑤	B3621	Adapter	For 3 inch
⑥	B3622	Rectangular nozzle	
⑦	B3623	Round nozzle	
⑧	B2418	Bench top hood	
⑨	B3625	Net	5 pcs.
⑩	B2410	Duct	For 3 inch (φ 75 mm)
⑪	B2416	Duct band	Set of 2

