

FUME EXTRACTION  
**Instruction Manual**

Thank you for purchasing the HAKKO FA-430 Fume Extractor.  
Please read this manual before operating the HAKKO FA-430.  
Keep this manual readily accessible for reference.

**1. PACKING LIST AND PART NAMES**

Please check to make sure that all items listed below are included in the package.

HAKKO FA-430 Fume extraction system.....	1	Main filter (inside main unit).....	1
Power cord.....	1	Pre-filter (inside main filter).....	1
Cap (inside main unit).....	1	Instruction manual.....	1

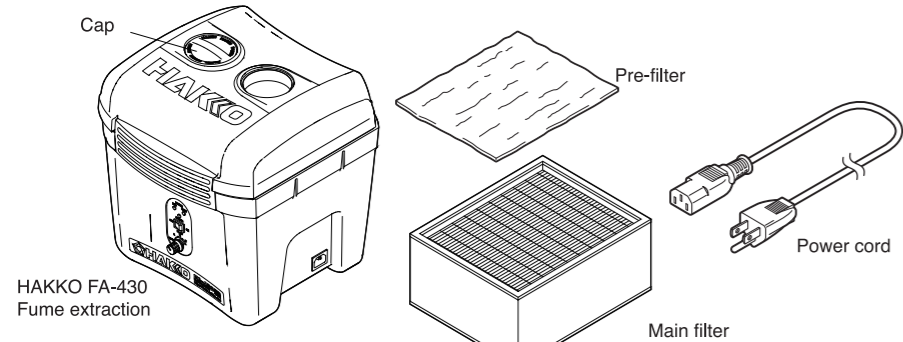

**●Duct set (not included)**

Duct set (Duct / Adapter / Rectangular nozzle or Round nozzle / Net)

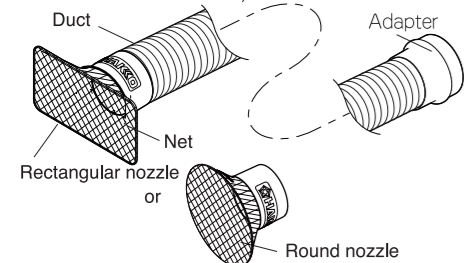

**●Option**

3 inch adapter



\*When using the 3 inch duct, set the 3 inch adapter to the main unit.

**2. SPECIFICATIONS**

**●HAKKO FA-430**

Power Consumption	120W		
Absorption Capacity *1	High	Medium	Low
	4.7m³/min	3.7m³/min	2.8m³/min
Collection Efficiency *2	98%		
Duct diameter	φ55 mm (2.2 in.)		
Dimensions	330(W) x 366(H) x 343(D) mm (13x14.4x13.5 in.)		
Weight (w/o cord)	7.5 kg (16.5 lb.)		

\*Specifications and design are subject to change without notice.

\*1 When using 2 ducts

\*2 Collection efficiency is measured in accordance with counting method using lithometeor.

**■ Electrostatic Protection**

This product includes such features as electrically conductive plastic parts and grounding of the unit as measures to protect the device to be soldered from the effects of static electricity. Be sure to observe the following instructions:

1. The plastic parts are not insulators, they are conductors. When making repairs or replacing parts, take sufficient care not to expose live electrical parts or damage insulation materials.
2. Be sure to ground the unit during use.

**HAKKO**  
**HAKKO CORPORATION**  
HEAD OFFICE  
TEL: +81-6-6561-3225 FAX: +81-6-6561-8466  
http://www.hakko.com E-mail:sales@hakko.com  
OVERSEAS AFFILIATES  
U.S.A.: AMERICAN HAKKO PRODUCTS, INC.  
TEL: (661) 294-0090 FAX: (661) 294-0096  
Toll Free (800)88-HAKKO  
http://www.hakkousa.com  
HONG KONG: HAKKO DEVELOPMENT CO., LTD.  
TEL: 2811-5688 FAX: 2590-0217  
http://www.hakko.com.hk  
E-mail:info@hakko.com.hk  
SINGAPORE: HAKKO PRODUCTS PTE., LTD.  
TEL: 6748-2277 FAX: 6744-0033  
http://www.hakko.com.sg  
E-mail:sales@hakko.com.sg

Please access to the following address for the other Sales affiliates.  
<http://www.hakko.com>  
Copyright © 2011 HAKKO Corporation. All Rights Reserved.

**3.WARNINGS, CAUTIONS, NOTES AND EXAMPLES**

**⚠ WARNING**

Warnings, cautions and notes are placed at critical points in this manual to direct the operator's attention to significant items. They are defined as follows:

**⚠ WARNING:** Failure to comply with a WARNING may result in serious injury or death.

**⚠ CAUTION :** Failure to comply with a CAUTION may result in injury to the operator, or damage to the items involved.

**NOTE :** A NOTE indicates a procedure or point that is important to the process being described.

**⚠ CAUTION**

This unit is approved for use as a non-flammable fume extraction system. Misuse of this product may result in damage to the unit or injury.

- Do not absorb combustible, explosive or corrosive gas.
- Store the fume extraction unit in a dry place.
- Do not block the exhaust vent of the fume extraction unit.
- Use only genuine HAKKO replacement parts.
- Turn the power off when not in use, or left unattended.
- Turn the power off when changing parts, replacing filters or storing the HAKKO FA-430.
- This appliance is not intended for use by persons (including children) with reduced physical, sensory or mental capabilities, or lack of experience and knowledge, unless they have been given supervision or instruction concerning use of the appliance by a person responsible for their safety.
- Children should be supervised to ensure that they do not play with the appliance.

- Do not operate the fume extraction without the filter; otherwise it may cause the unit to malfunction.
- Hold the plug when inserting or removing the cord in/from the outlet.
- Do not allow the HAKKO FA-430 to become wet, or use it with wet hands.
- While using the HAKKO FA-430, don't do anything which may cause bodily harm or physical damage.

**4. OPERATION**

**●Attach the duct**

**A. How to attach duct set**

1. Refer to Figure 1(right), and attach the nozzle and adapter to the duct. Insert the nozzle and adapter until it stops, turn the nozzle clockwise. Make sure the nozzle and adapter are firmly attached.

**⚠ CAUTION**  
Twist the nozzle tight enough to avoid coming off.

2. Fit the net on the nozzle. (Figure.2)

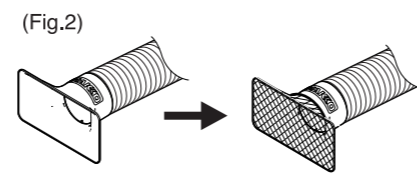

3. Insert the duct into the open port. If using one duct, ensure the cap is in place on the unused port. When using two ducts, please store the cap inside the main unit next to the main filter as shown in Figure 3 (right).

**B. How to attach bench top hood.**

When using a bench top hood, the following parts are required:

- 3 inch adapter
- 3 inch duct
- Duct clamp

\*The standard duct for the HAKKO FA-430 can not be used to connect a bench top hood.

(Fig.1)

Be sure the duct is facing in the proper direction during assembly.

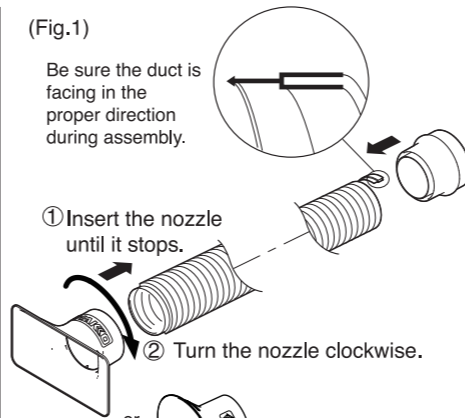

(Fig.3)

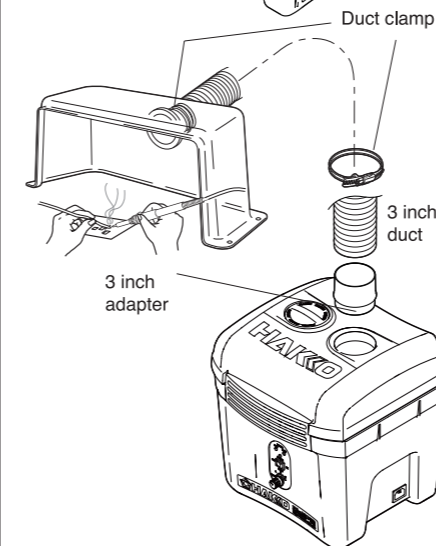
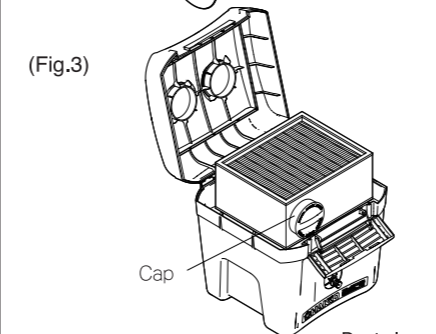

**4. OPERATION**

**●Fume extraction unit**

1. Connect the power cord to the power receptacle on the right of the unit.
2. Plug the power cord into a ground wall socket.
3. Turn the power switch on. Power lamp will light up.

**⚠ CAUTION**  
Close the cover before turning the power switch on.

**⚠ CAUTION**  
●Do not block the open port on purpose.  
●When the fan is running, do not open the upper cover.  
●Turn the power off when not in use.  
Failure to do so may result in shorter filter life.  
●If it passes more than 2000 hours or one year since the HAKKO FA-430 is used, replace the main filter with new one at once.  
If using the main filter over replacement timing, doing so may result in damage to the main unit.

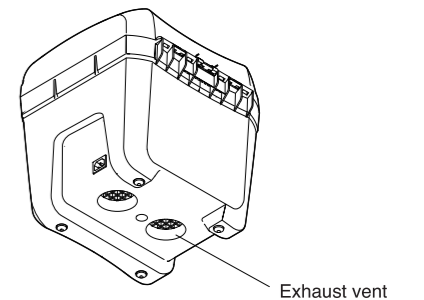
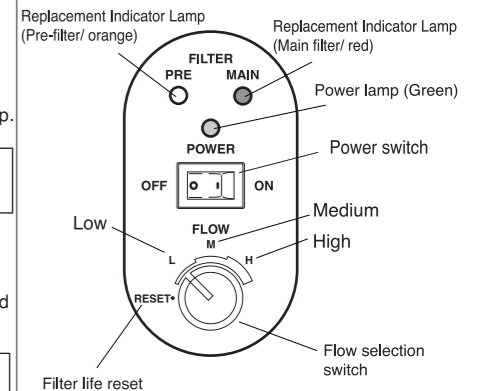

**●How to set the filter**

\*The pre-filter and the main filter are pre-installed in the unit (without plastic bags) for your immediate use when delivered.

1. Open the upper cover.
2. Put the main filter on the main unit. Set the filter with the arrow pointing down (as shown in the illustration).
3. Fit the pre-filter on top of the main filter.

**⚠ CAUTION**  
Be sure the pre-filter lies flat and completely covers the top of the main filter with no gaps.

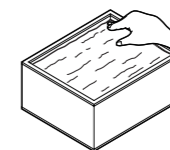

4. Close the upper cover.

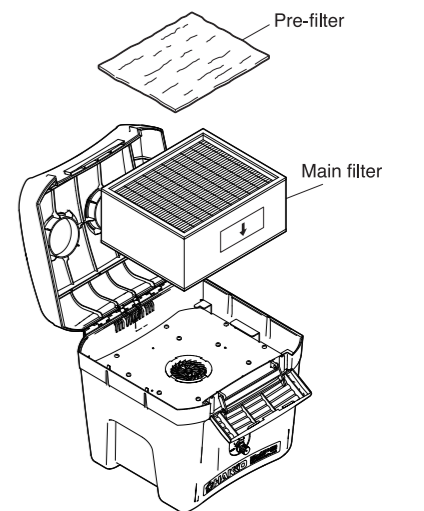

\* 各言語（日本語、英語、中国語、フランス語、ドイツ語、韓国語）の取扱説明書は以下のURL、HAKKO Document Portalからダウンロードしてご覧いただけます。  
(商品によっては設定の無い言語がありますが、ご了承ください)  
\* 各言語(日本語、英語、中文、法語、德語、韓語)の使用説明書可以通过以下网站的HAKKO Document Portal 下载参阅。  
(有一部分的产品没有设定外语对应,请见谅)  
• Instruction manual in the language of Japanese, English, Chinese, French, German and Korean can be downloaded from the HAKKO Document Portal.  
(Please note that some languages may not be available depending on the product.)

<https://doc.hakko.com>

**中國RoHS: 產品中有毒有害物質或元素的名稱及含量**

部件名稱	有毒有害物質或元素					
	鉛(Pb)	汞(Hg)	鎘(Cd)	六價鉻 (Cr(VI))	多溴聯苯 (PBB)	多溴二苯醚 (PBDE)
風扇組合	×	○	○	○	○	○
插頭	×	○	○	○	○	○

○ : 表示該有毒有害物質在該部件所有均質材料中的含量均在SJ/T 11363-2006 標準規定的限量要求以下。  
× : 表示該有毒有害物質至少在該部件的某一均質材料中的含量超出SJ/T 11363-2006 標準規定的限量要求。

## 5. MAINTENANCE

Performing proper and periodic maintenance extends the product life. Wear of the product will differ depending on work environment, the quality and quantity of the solder and flux. Apply the following service procedure as dictated by the conditions of the usage.

HAKKO FA-430 counts used number of the pre-filter in order to determine the remaining life of the main filter. There are a few points to observe when replacing filters. Read "How to replace the filter" and follow the procedure. Replacing the filter without following the procedure may cause the overuse of the main filter and subsequent damage to the unit.

### ●Filter replacement timing

**Pre-filter :** 80% of the pre-filter is clogged or it was used for 160 hours. (The orange lamp flashes.)

**Main filter :** You have replaced the pre-filter 10 times, and the current pre-filter is 80% clogged or has been used for 160 hours. (The orange and red lamp flash.)

#### ⚠ CAUTION

Replacing the filter without following the procedure will disrupt the timing for filter replacement and may cause the overuse of the filters and subsequent damage to the unit.

### ●How to replace the filter

#### NOTE:

- The lamp status indicates appropriate time to replace the main filter and pre-filter. If continuing to use the main filter or pre-filter after the lamp status indicates it is time for replacement, it may result in reduced performance and/or subsequent damage to the unit.
- When replacing the filter, set the flow selection switch to RESET without turning off the power switch.

#### A. Pre-filter

#### NOTE:

Do not lift the main filter when replacing the pre-filter. If the main filter is lifted for more than 3 seconds with the power switch on and the flow control set to RESET, the used number of the pre-filter are reset to zero.

- ① Pre-filter lamp (orange) flashes.
- ② Set the flow selection switch to RESET with the power switch on. (The fan will stop.)
- ③ Open the upper cover and remove the pre-filter only. Fit the new pre-filter on top of the main filter so that it lies flat with no gaps, then close the upper cover.
- ④ Set the flow selection switch back to the previous position. The fan will start running and the unit will return to a normal operating condition.

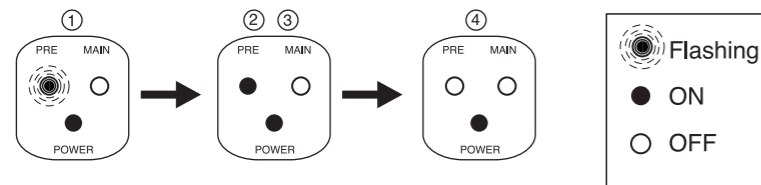

#### B. Main filter

- ① Pre-filter lamp (orange) and main filter lamp (red) flash.
- ② Set the flow selection switch to RESET with the power switch on. (The fan will stop.)
- ③ Open the upper cover and then remove both main filter and pre-filter. Replace the filters with the new filters, fit them in the main unit and close the upper cover.
- ④ Set the flow selection switch back to the previous position. The fan will start running and the unit will return to a normal operating condition.

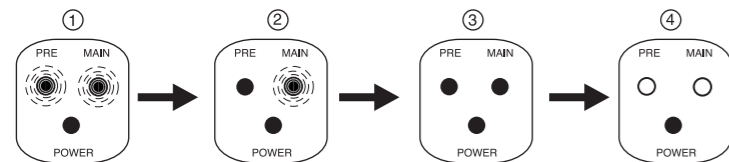

\*Pre-filter lamp (orange) and main filter lamp (red) flash, but if you can not replace the main filter immediately, observe the following procedure.

- ① Pre-filter lamp (orange) and main filter lamp (red) flash.
- ② Set the flow selection switch to RESET with the power switch on. (The fan will stop.)
- ③ Open the upper cover and then remove the pre-filter only. Fit the new pre-filter on top of the main filter so that it lies flat with no gaps, then close the upper cover.
- ④ Set the flow selection switch back to the previous position. After 5 seconds are passed, the red lamp will be turned off.

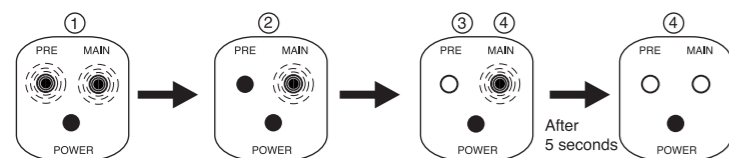

#### ⚠ CAUTION

Main filter lamp (red) will flash for 5 seconds every time the power switch is turned on. Performance of the main filter is reduced. Replace it at once.

## 6. TROUBLE SHOOTING GUIDE

●Nothing happens when the power switch is turned on.

**CHECK :** Is the power cord disconnected ?

**ACTION :** Connect it.

**CHECK :** Is the main filter set properly ?

**ACTION :** Fit the main filter properly before turning on the power switch again.

**CHECK :** Is the flow control set to RESET ?

**ACTION :** Adjust the flow suitable for working environment by using the flow selection switch.

●Orange lamp keeps flashing after replacing the pre-filter.

**CHECK :** When replacing the filter, Is the flow selection switch adjusted to RESET with the power switch on ?

**ACTION :** Make sure that power switch is ON, and set the flow selection switch to RESET again.

●Red lamp keeps flashing after replacing the main filter.

**CHECK :** When replacing the filter, Is the flow selection switch adjusted to RESET with the power switch on ?

**ACTION :** Make sure that power switch is on and set the flow selection switch to RESET. Lift the main filter more than 3 seconds.

●Red lamp is flashing for 5 seconds just after turning the power switch on.

**ACTION :** Main filter needs to be replaced. Recommend replacing the main filter otherwise performance will be reduced.

●Red lamp lights up.

**ACTION :** Main filter has exceeded its service life and was never replaced. It has passed more than 2000 hours since it is used. Main filter must be replaced. Failure to do so may result in damage to the unit.

●All lamp flashes at the same time.

**ACTION :** Service Required. Contact your HAKKO representative.

## 7. PARTS LIST

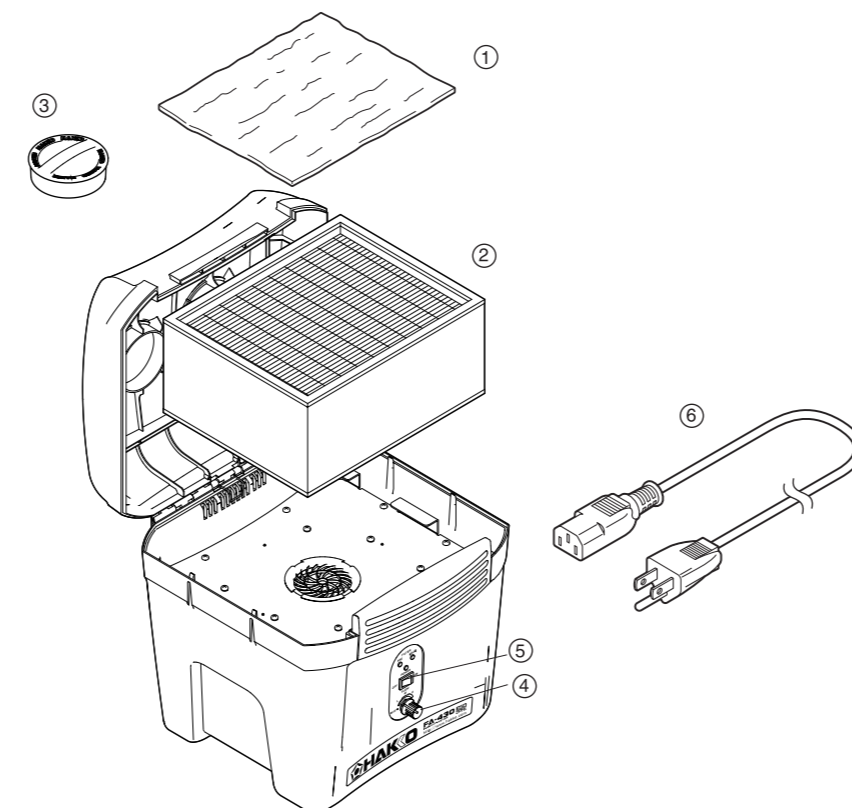

## 7. PARTS LIST

### ●HAKKO FA-430

Item No.	Part No.	Part Name	Specifications
①	A1585	Pre-filter	10 pcs.
②	A1586	Main filter	
③	B3619	Cap	
④	B1486	Knob	
⑤	B2852	Power switch	
⑥	B3641	Power cord, 3 wired cord & American plug	120V

### ●Option

Item No.	Part No.	Part Name	Specifications
①	C1571	Duct set / Rectangular nozzle	Duct (1) / Adapter (1) Rectangular nozzle(1) / Net (1)
②	C1572	Duct set / Round nozzle	Duct (1) / Adapter (1) Round nozzle (1) / Net (1)
③	B3642	Duct	1.2 m, φ 55 mm
④	B3620	Adapter	For standard duct
⑤	B3621	Adapter	For 3 inch duct
⑥	B3622	Rectangular nozzle	
⑦	B3623	Round nozzle	
⑧	B3625	Net	5 pcs.

